

Perkins 1106A-70TAG3 diesel engine

Newage/Stamford UCI274G alternator

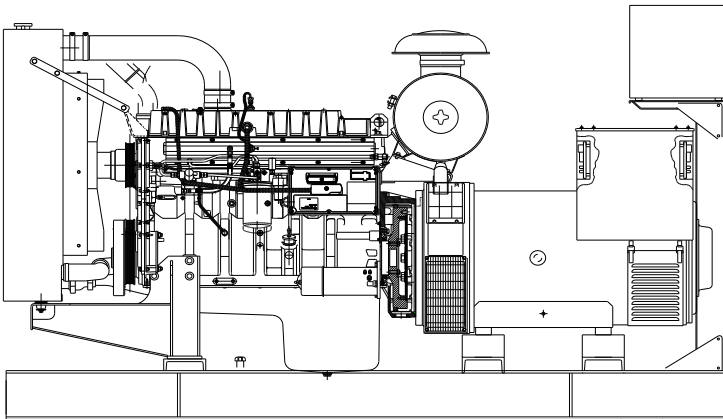

Standard Generator Features

- ◊ AMF, Automatic mains failure unit
- ◊ Heavy duty type, 6 cylinder, water cooled engine
- ◊ 50°C tropical type radiator
- ◊ Starter motor
- ◊ Lead acid battery
- ◊ Charging alternator
- ◊ Battery charge redressor
- ◊ Heavy duty, brushless type alternator
- ◊ Base frame with anti-vibration units
- ◊ Industrial type silencers
- ◊ Flexible exhaust compensator
- ◊ Block water heater unit
- ◊ Control panel with digital-automatic main control module
- ◊ Fan, fan drive, charging alternator drive and all rotating parts covered
- ◊ Radiator matrix covered by metal mesh against the mechanical damages
- ◊ Fabricated and welded steel base frame
- ◊ Anti-vibration mountings
- ◊ Engine and alternator manufacturer test reports
- ◊ Factory load, performance and function tests

Optional Features

- ◊ Automatic load transfer panel
- ◊ Automatic synchronization and power sharing systems
- ◊ Soundproof canopy
- ◊ Container type enclosures
- ◊ Road trailer
- ◊ Job-site trailer
- ◊ Protection circuit breaker
- ◊ Air start
- ◊ Remote type radiator
- ◊ Base fuel tank
- ◊ External type fuel tank
- ◊ Automatic fuel transfer system
- ◊ Residential silencer



Model	Standby		Prime	
	kVA	kW	kVA	kW
CJ200PN	200	160	181,9	145,5

APPLICATION DATA

Perkins 1106A-70TAG3 Engine

Standard Features

State of the Art Design

The 1106A-70TAG3 incorporates the latest common-rail fuel system technologies with a closely optimised air-management system which is overseen by the latest generation of electronic engine control. This allows the 1106A ElectropaK range to deliver high power density, low exhaust emissions with the minimum of heat rejection and excellent fuel economy.

Electronic engine control system is optional equipment

Worldwide Power Solution

The 1106A has been designed to be worldwide fuel tolerant, including kerosene, jet aviation fuel and 5% biofuel (RME). Options are available to meet local market needs.

Product Support

Perkins actively pursues product support excellence by ensuring our distribution network invest in their territory - strengthening relationships and providing more value to you, our customer

Through an experienced global network of distributors and dealers, fully trained engine experts deliver total service support around the clock, 365 days a year. They have a comprehensive suite of web based tools at their fingertips covering technical information, parts identification and ordering systems, all dedicated to maximising the productivity of your engine

Throughout the entire life of a Perkins engine, we provide access to genuine OE specification parts and service. We give 100% reassurance that you receive the very best in terms of quality for lowest possible cost. Wherever your Perkins powered machine is operating in the world

Model	Standby kW		Prime kW	
	Gross	Net	Gross	Net
1106A-70TAG3	180.2	175.2	162.7	157.7

Lubricating System

Type	Pressurized
Max. total system oil capacity, Liters	18
Lub oil pressure (min), kPa	430
◊ Flat-bottomed isolated aluminium sump	
◊ Oil filter	

Fuel System

Injection components

Injector	mechanic
Fuel Pump	DP210
Max. fuel flow	1.5 l/min
Maximum static pressure head	600 kPa
Tolerance on fuel consumption	3%
◊ Electronic governing (confirms to Class G2 ISO 8528-5)	
◊ Fuel filter	

Technical Specifications

Manufacturer	PERKINS
Model	1106A-70TAG3
Type	4 cycle, water-cooled, diesel engine
Number of cylinders	6
Displacement, Liters	7,01
Bore X Stroke, mm	105 mm x 135 mm
Compression Ratio	16:01
Combustion System	Direct injection
Aspiration	Turbocharged, air to air charge cooled
Rotation	Anti-clockwise, viewed on flywheel
Gross engine power, kWb	180.2
Energy to cooling fan kWm	5
BMEP gross, bar	2056,5
Combustion air flow, m ³ / min	13.87
Exhaust gas temp. (after turbo), °C	491
Exhaust gas flow (after turbo), m ³ / min	33,85
Mean piston speed, m / s	6,8

Electrical System

Alternator	12 volts
Starter motor (DC)	12 volts
◊ 12 volt starter motor 5kW	
◊ 12 volt, 65 amp alternator with DC output	

Fuel Consumption

liters per hour	%110 Load	45.1 L
	%100 Load	41.4 L
	%75 Load	32.0 L
	%50 Load	20.2 L
grams per kWh	%110 Load	207.3 g/kWh
	%100 Load	209.2 g/kWh
	%75 Load	211.3 g/kWh
	%50 Load	200.2 g/kWh

Cooling System

Type	Tropical, heavy duty type
Ambient temperature, °C	50
Total system capacity	21
Max. permissible external sys. res., kPa	35
◊ 610mm belt-driven pusher fan and guards	
◊ Radiator (incorporating air-to-air charge cooler + fuel cooler)	
◊ Water pump	

alternator

Newage/Stamford UCI274G Alternator

Standard Features

Winding&Electrical Performance

All generator stators are wound to 2/3 pitch. This eliminates triplen (3rd, 9th, 15th...) harmonics on the voltage waveform and is found to be the optimum design for trouble-free supply of non-linear loads. The 2/3 pitch design avoids excessive neutral currents sometimes seen with higher winding pitches, when in parallel with the mains. A fully connected damper winding reduces oscillations during paralleling. This winding, with the 2/3 pitch and carefully selected pole and tooth designs, ensures very low waveform distortion.

SX460 AVR

With this self-excited system the main stator provides power via the Automatic Voltage Regulator (AVR) to the exciter stator. The high efficiency semi-conductors of the AVR ensure positive build-up from initial low levels of residual voltage.

The exciter rotor output is fed to the main rotor through a three-phase full-wave bridge rectifier. The rectifier is protected by a surge suppressor against surges caused, for example, by short circuit or out-of-phase paralleling.

The SX440 will support a range of electronic accessories, including a 'droop' Current Transformer (CT) to permit parallel operation with other ac generators. If 3-phase sensing is required with the self-excited system, the SX421 AVR must be used.

Terminals&Terminal Box

Standard generators are 3-phase reconnectable with 12 ends brought out to the terminals, which are mounted on a cover at the non-drive end of the generator. A sheet steel terminal box contains the AVR and provides ample space for the customer's wiring and gland arrangements. It has removable panels for easy access.

Shaft&Keys

All generator rotors are dynamically balanced to better than BS6861:Part 1 Grade 2.5 for minimum vibration in operation. Two bearing generators are balanced with a half key.

Insulation / Impregnation

The insulation system is class 'H'

All wound components are impregnated with materials and processes designed specifically to provide the high build required for static windings and the high mechanical strength required for rotating components.

Standards

Newage Stamford industrial generators meet the requirements of **BS EN 60034** and the relevant section of other international standards such as **BS5000, VDE0530, NEMA MG1-32, IEC34, CSA C22.2-100, AS1359**. Other standards and certifications can be considered on request.

Quality Assurance

Generators are manufactured using production procedures having a quality assurance level to BS EN ISO 9001.

Model	Standby		Prime	
	kVA	kW	kVA	kW
UCI274G	200	160	182	146

Technical Specifications

Manufacturer	NEWAGE / STAMFORD
Model	UCI274G
Type	4-Poles, Rotating Field, Brushless
Standby power at rated voltage, kVA	200
Efficiency, %	%92.0
Power factor	0.8
Phase	3
Frequency, Hz	50
Speed, Rpm	1500
Voltage, V	380/415
Excitation	Self excited
Stator windings	2/3 Pitch factor
Regulation	AVR, Automatic Voltage Regulator
Voltage Regulator	SX460
Voltage Regulation, %	± 1
R.F.I Suppression	BS EN 61000-6-2 & BS EN 61000-6-4 VDE0875G, VDE 0875N
Waveform distortion	No Load <1.5% Non distorting balanced linear load <5.0%
Rotor	Dynamic balanced
Overspeed, Rpm	2250
Short circuit current	< 300%
TIF	Less than 50
Insulation class	H
Construction	Single bearing, direct coupled
Coupling	Flexible
Stator winding	Double layer concentric
Connection	WYE
Protection class	IP23
Cooling air volume, m ³ / sec	0.514

Optional Equipment

- ◊Anti Condensation Heaters
- ◊Air Filters
- ◊Temperature Indication RTD's
- ◊Winding Protection Thermistors
- ◊Quadrature Droop kit for Parallel Operation
- ◊SX440 AVR with 1% Regulation and 2 Phase Sensing
- ◊SX421 AVR with 3 Phase Sensing and improved Regulation 0.5%
- ◊MX341 (PMG) 1% Regulation with 2 Phase Sensing
- ◊MX321 (PMG) with 3 Phase Sensing and improved Regulation 0.5%

Control Panel

Standard Equipments

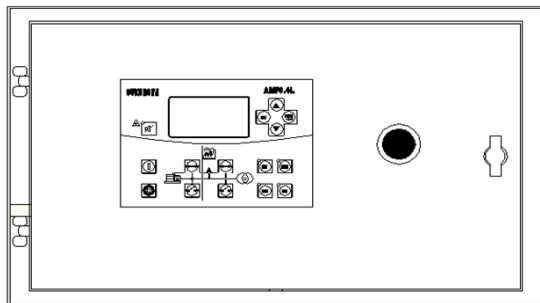

- ◊ AMF 3.4L graphical LCD display with white back light
- ◊ Emergency stop button

AMF 3.4L Control Module

Description

- ◊ The model AMF 3.4L is an automatic mains failure control module.
- ◊ The modul is used to monitor a mains supply and automatically start a standby generator set.
- ◊ The module also provides indication of operational status and fault conditions
- ◊ automatically shutting down the genset and indicating failures by means of an LCD display, and appropriate flashing LED on the front panel.
- ◊ Selected timers and alarms can be altered by the user from the front panel.
- ◊ Phase sequence detection and reverse power detection.
- ◊ Real time clock and time stamped alarm logging

◊

Specifications

- ◊ 17,85mm x 125,6mm dimensions
- ◊ 128x64 screen LED display.
- ◊ IP52
- ◊ Easy comprehended display .
- ◊ LED mimic diagram
- ◊ Easy pushbutton controls
- ◊ System parameters can be adjusted manually from the front panel
- ◊ kVA, kW ve $\cos\phi$ measurements
- ◊ Recording of the last 15 failure alarm.
- ◊ Battery saving sleep mode function.
- ◊ Pre-glow heater control
- ◊ True RMS voltage and current measurements for mains and generator.
- ◊ 8 digital inputs , 6 digital outputs (Dry Contact)

Pushbutton Controls

STOP / START
 AUTO, TEST, MANUAL
 LCD PAGE

Input Functions display on LCD

Generator Volts	Volts L1-N, L2-N, L3-N
Generator Volts	Volts L1-L2, L2-L3, L3-L1
Generator Amps	Amps L1, L2, L3
Generator Frequency	Hz
Mains Volts	Volts L1-N, L2-N, L3-N
Mains Volts	Volts L1-L2, L2-L3, L3-L1
Mains Kva, Kw, Kvar, Kvarh	L1-N, L2-N, L3-N
Generator Kva, Kw, Kvar, Kvarh	L1-N, L2-N, L3-N
Power Factor	cos ϕ
Mains Frequency	Hz
Engine Speed	RPM
Plant Battery Volts	Volts
Engine Hours Run	Hour

Optional Functions

Engine Oil pressure	kPa
Engine Temperature	°C
Service Hours Timing Function	
SCADA Interface For Monitoring And Remote System Programming	
GSM Modem Interface (SMS options)	
Remote Start-Stop Interface	
Modbus Rtu Communication Interface Port	

Alarm Channels

Engine Start/Stop Failure
Over-Current
Under/Over Generator Frequency
Under/Over Speed
Charge Fail
Emergency Stop
Low Oil Pressure
High Engine Temperature
Under/Over Generator Voltage
Loss Of Speed Sensing Signal
Mains Out Of Limits

Environmental Testing Standards

Electromagnetic Compatibility

K-Q TSE ISO 9000

Temperature

Cold : -25°C

Hot : + 70°C

Humidity

%10-95 non-condensing

Model Codes and General Information

Cukurova Diesel Generator

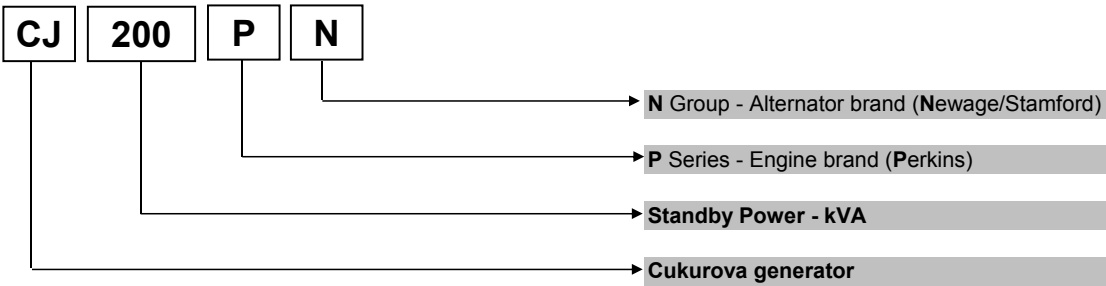

Perkins 1100 Series Diesel Engine

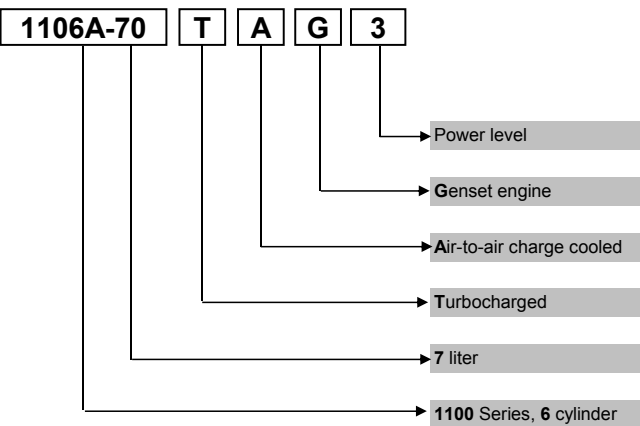

Newage / Stamford Alternator

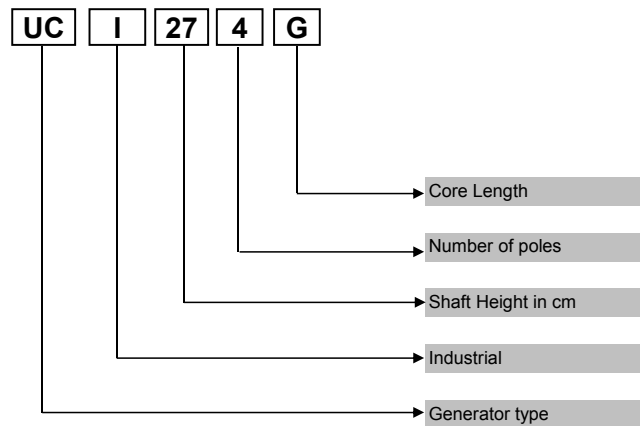

Information

Power Ratings

Standby power rating is for the supply of emergency power at variable load for the duration of the non-availability of the mains power supply. No overload capacity is available at this rating. A standby rated engine should be sized for an average load factor of 80% based on published standby rating for 500 operating hours per year. Standby ratings should never be applied except in true emergency power failure conditions.

Prime power rating is available for unlimited hours per year with a variable load of which the average engine load factor is 80% of the published power rating, incorporation of a 10% overload for 1 hour in every 12 hours of operation which permitted

Continuous power rating is available for continuous full load operation. No overload is permitted.

Acc. to ISO 3046/1, BS 5514, DIN6271

Electric Formulas

Values	Formula	
kWe	kWm X E	
kWe	$(U \times I \times 1.73 \times pf) / 1000$	kVA x pf
kVA	$(U \times I \times 1.73) / 1000$	kWe / pf
I (Amp)	$(kWe \times 1000) / (U \times 1.73 \times pf)$	$(kVA \times 1000) / (U \times 1.73)$
Frequency	$(Rpm \times N^{\circ}Pole) / (2 \times 60)$	
Rpm	$(2 \times 60 \times Frequency) / N^{\circ}Pole$	

kWm: Mechanical Power
kWe : Electrical Power
pf : Power factor
E : Alternator efficiency

I : Current (A)
U : Voltage (V)
kVA : Power
Rpm: Revolutions per minute

