

Volvo TAD733GE diesel engine

Sincro SK250MM alternator

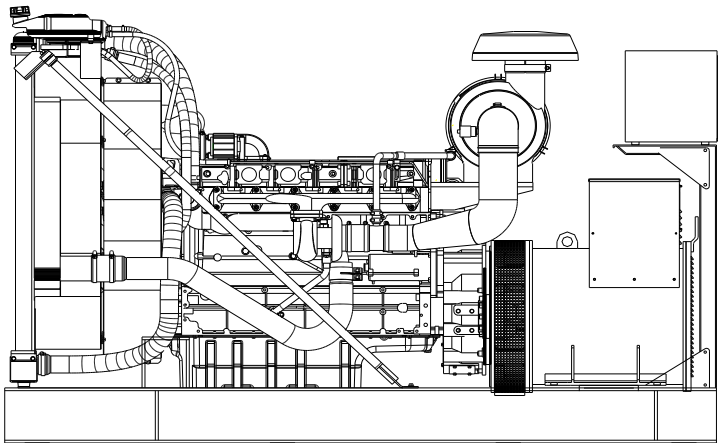

Standard Generator Features

- ◊ AMF, Automatic mains failure unit
- ◊ Heavy duty type, 6 cylinder, water cooled engine
- ◊ 50°C tropical type radiator
- ◊ Starter motor
- ◊ Lead acid battery
- ◊ Charging alternator
- ◊ Battery charge redressor
- ◊ Heavy duty, brushless type alternator
- ◊ Base frame with anti-vibration units
- ◊ Industrial type silencers
- ◊ Flexible exhaust compensator
- ◊ Block water heater unit
- ◊ Control panel with digital-automatic main control module
- ◊ Fan, fan drive, charging alternator drive and all rotating parts covered
- ◊ Radiator matrix covered by metal mesh against the mechanical damages
- ◊ Fabricated and welded steel base frame
- ◊ Anti-vibration mountings
- ◊ Engine and alternator manufacturer test reports
- ◊ Factory load, performance and function tests

Optional Features

- ◊ Automatic load transfer panel
- ◊ Automatic synchronization and power sharing systems
- ◊ Soundproof canopy
- ◊ Container type enclosures
- ◊ Road trailer
- ◊ Job-site trailer
- ◊ Protection circuit breaker
- ◊ Air start
- ◊ Remote type radiator
- ◊ Base fuel tank
- ◊ External type fuel tank
- ◊ Automatic fuel transfer system
- ◊ Residential silencer



Model	Standby		Prime	
	kVA	kW	kVA	kW
CJ225VS	218	174,4	200	160

APPLICATION DATA

Volvo TAD733GE Engine

Standard Features

The TAD733GE is a powerful, reliable and economical Generating Set Diesel built on the dependable in-line six design.

Low exhaust emission

The state of the art, high-tech injection and charging system with low internal losses contributes to excellent combustion and low fuel consumption. The TAD733GE complies with EU Stage 2 and, TA-Luft exhaust emission regulations.

Easy service & maintenance

Easily accessible service and maintenance points contribute to the ease of service of the engine.

Engine and Block

- ◊Piston cooling for low piston temperature and reduce ring temperature
- ◊Drop forged steel connecting rods
- ◊Keystone top compression rings for long service life
- ◊Replaceable valve guides and valve seats
- ◊Three PTO positions at flywheel
- ◊Lift eyelets
- ◊Flywheel housing with connection acc.to SAE2
- ◊Flywheel for flexible coupling and striction clutch
- ◊Transport brackets
- ◊
- ◊
- ◊

Technical Specifications

Manufacturer	VOLVO
Model	TAD733GE
Type	4 cycle, water-cooled, diesel engine
Number of cylinders	6
Cylinder arrangement	Vertical in-line
Displacement, Liters	7.15
Bore X Stroke, mm	108 X 130
Compression Ratio	18.1:1
Combustion System	Direct injection
Aspiration	Turbocharged, air-to-air charge cooled
Rotation	Anti-clockwise viewed on flywheel
Gross engine power, kWb	201
Fan Power, kWm	6
BMEP gross, Mpa	2,3
Exhaust gas temp.(after turbo), °C	530
Exhaust gas flow (after turbo),m³ / min	37,2
Mean piston speed, m / s	6.5

Model	Standby kW		Prime kW	
	Gross	Net	Gross	Net
TAD733GE	201	195	181	175

Cooling System

Type	Tropical, heavy duty type
Ambient temperature, °C	50
Engine+Radiator coolant cap., Liters	38
Jacket coolant flow, Liters / sec	3.0

- ◊Tropical radiator incl intercooler
- ◊Gear driven coolant pump
- ◊Fan hub
- ◊

Electrical System

Alternator	1x35A/24V,low left
Starter motor (DC)	Melco, 24V
Starter motor power	5,0kW

Fuel System

Type of injection system	Direct injection
Fuel injector	Electronic unit injector
Governor type	Heinzmann / EDC4
◊Six hole fuel injection nozzles	Heinzmann / EDC4
◊Direct injection unit pumps	
◊	
◊	

Fuel Consumption

gram per kWhour	% 100 Load	219 g/kWh
	%75 Load	215 g/kWh
	%50 Load	216 g/kWh
	%25 Load	228 g/kWh

Lubricating System

Type	Pressurized
Capacity, Liters	34
Lub oil pressure ,kPa	480
◊Rotary type lubrication oil pump driven by crankshaft	
◊Full flow disposable spin-on oil filter, for extra high filtration	
◊Deep centre oil sump driven by the crankshaft	
◊Oil filter on top	
◊	
◊	

alternator

Sincro SK250MM Alternator

Standard Features

Electrical performance

Class H insulation

Windings are vacuumed under pressurized polyester resin and varnished

Standard 12-wire re-connectable winding, 2/3 pitch

High efficiency and motor starting capacity

Protection degree

Sincro alternators are standard IP23

All the rotating and electrically energized parts are fully guarded.

Higher protection degree can be supplied on request

Costruction

Single bearing design

Bearings are dimensioned for heavy duty

Steel frame

Cast iron flanges and shields

Automatic Voltage Regulator

BL4 automatic voltage regulator provides 1 % regulation and underspeed protection

Transient features

Transient voltage drop for rated step load at 0.8 power factor is less than 18%

Single phase operation

All brushless alternators can be connected for single phase use

Standards

Sincro alternators conforms to the main international standards and regulations:

IEC 34.1, IEC 34.5, IEC 34.22, EN55011, EN50081-1, EN50082-2

Model	Standby		Prime	
	kVA	kW	kVA	kW
SK250MM	218	176	200	160

Technical Specifications

Manufacturer	SINCRO
Model	SK250MM
Type	4-Poles, Rotating Field, Brushless
Standby power at rated voltage, kVA	218
Efficiency, %	91.9
Power factor	0.8
Phase	3
Frequency, Hz	50
Speed, Rpm	1500
Voltage, V	400
Excitation	Self excited
Stator windings	2/3 Pitch factor
Regulation	AVR, Automatic Voltage Regulator
Voltage Regulator	BL 4
Voltage Regulation, %	± 1
THC	< 2%
THF	< 3%
Short circuit current	>300 % In
Insultion class	H
Leads	12
Construction	Single bearing, direct coupled
Connection	WYE
Protection class	IP23

Optional Equipment

- ◊N° 3 Thermal contacts N.C. (N.O. On request)
- ◊Protection IP23
- ◊Protection IP44 (90 % of output power)
- ◊N° 1 PT100 on the bearing
- ◊Tropicalized winding
- ◊Device for parallel operation with other alternators
- ◊Space heaters 230V
- ◊N° 3 Thermistor PTC
- ◊N° 3 Thermoresistors PT100
- ◊N° 1 Potentiometer for voltage remote control
- ◊Special voltages

Control Panel

Standard Equipments

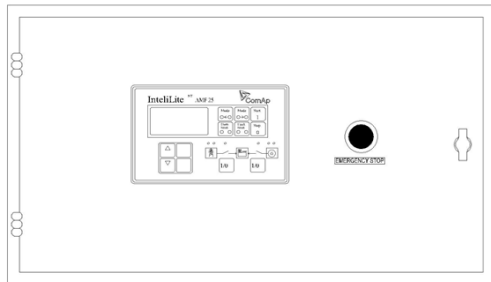

- ◆ ComAp IntelliLiteNT AMF25 digital automatic control module
- ◆ Emergency stop button
- ◆
- ◆
- ◆
- ◆

ComAp IntelliLiteNT AMF25 Control Module

Description

- ◆ The model AMF25 is an Automatic Mains Failure Control module.
- ◆ The modul is used to monitor a mains supply and automatically start a standby generator set.
- ◆ The module also provides indication of operational status and fault conditions automatically shutting down the genset and indicating failures by means of an LCD display, and appropriate flashing LED on the front panel.
- ◆ Selected timers and alarms can be altered by the user from the front panel.
- ◆ Alterations to the system are made using USB and a PC. This interface also provides real time diagnostic facilities

◆

Specifications

- ◆ 180mm x 120mm dimensions
- ◆ Graphic 128 x 64 pixel display
- ◆ Developed 16-bit Microprocessor design
- ◆ Easy comprehended display
- ◆ LED mimic diagram
- ◆ SMS messaging capability with suitable GSM Modem
- ◆ PC software is MS Windows based and allows the operator to control the module from a remote location (with USB)
- ◆ Easy pushbutton controls
- ◆ System parameters can be adjusted manually from the front panel
- ◆ kVA, kW ve Cosφ measurements
- ◆ Communication with MODEM / Ethernet
- ◆ Modbus RTU
- ◆ User selectable RS232 or RS485 communications.
- ◆ 3 analog inputs, 7 digital inputs, 7 digital outputs

Pushbutton Controls

STOP / START
 AUTO, TEST, MANUAL MODE SELECTOR
 LCD PAGE

Input Functions display on LCD

Generator Volts	Volts L1-N, L2-N, L3-N
Generator Volts	Volts L1-L2, L2-L3, L3-L1
Generator Amps	Amps L1, L2, L3
Generator Frequency	Hz
Mains Volts	Volts L1-N, L2-N, L3-N
Mains Volts	Volts L1-L2, L2-L3, L3-L1
Mains Frequency	Hz
Engine Speed	RPM
Plant Battery Volts	Volts
Engine Hours Run	Hour
Generator Total Power	kVA L1, L2, L3,total
Generator Total Power	kW L1, L2, L3,total
Generator Power Factor	Cosφ L1, L2, L3,total

Analog Input Functions

Engine Oil pressure	kPa
Fuel Level	%
Engine Temperature	°C

Alarm Channels

Under/Over Generator Voltage
 Over-Current
 Under/Over Generator Frequency
 Under/Over Speed
 Charge Fail
 Emergency Stop
 Low Oil Pressure
 High Engine Temperature
 Fail to Start
 Low/High DC Battery Voltage
 Generator Phase Rotation Error
 Loss of Speed Sensing Signal
 Mains Out of Limits

Environmental Testing Standards

Electromagnetic Compatibility

BS EN 50081-2:1992 and EN 61000-6-4:2000 EMC, Emission Standards for the Industrial Environment

EN 61000-6-2:1999 EMC, Immunity Standards for the Industrial Environment

Temperature

Cold : BS EN 60068-2-1 to -20°C/-40°C

Hot : BS EN 60068-2-2 to 70°C

Electrical Safety

BS EN 60950 Low Voltage Directive/Safety of information technology equipments, including electrical business equipment

Optional Accessories

RS232 Extension Board
 RS485 Extension Board
 Ethernet Plug-in Module
 GSM Plug-in Module
 Remote Annunciator

Model Codes and General Information

Cukurova Diesel Generator

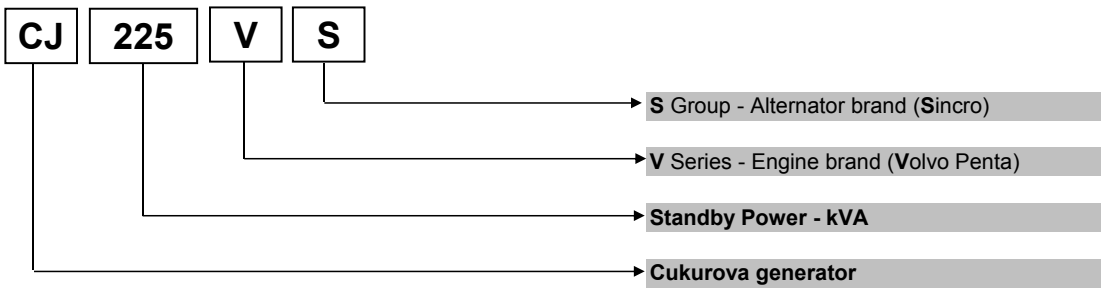

Volvo Penta Diesel Engine

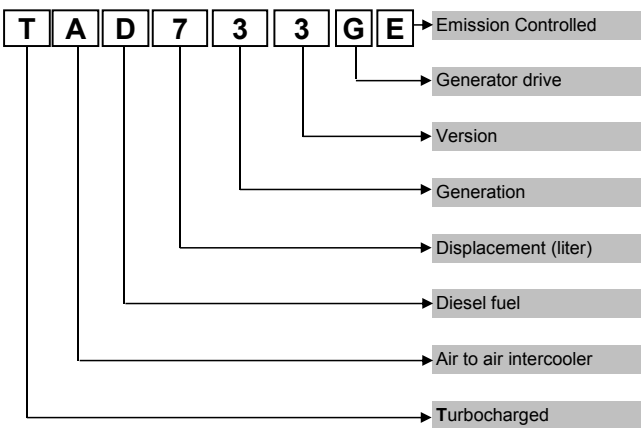

Sincro Alternator

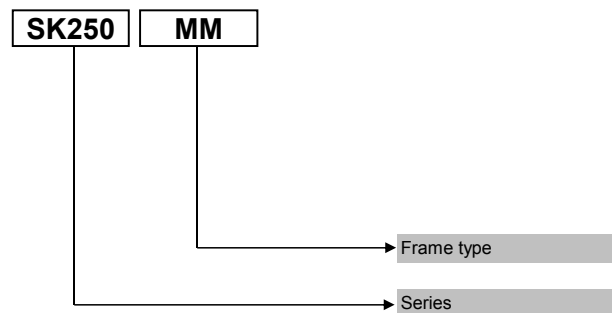

Information

Power Ratings

Standby power rating is for the supply of emergency power at variable load for the duration of the non-availability of the mains power supply. No overload capacity is available at this rating. A standby rated engine should be sized for an average load factor of 80% based on published standby rating for 500 operating hours per year. Standby ratings should never be applied except in true emergency power failure conditions.

Prime power rating is available for unlimited hours per year with a variable load of which the average engine load factor is 80% of the published power rating, incorporation of a 10% overload for 1 hour in every 12 hours of operation which permitted

Continuous power rating is available for continuous full load operation. No overload is permitted.

Acc. to ISO 3046/1, BS 5514, DIN6271

Electric Formulas

Values	Formula	
kWe	kWm X E	
kWe	$(U \times I \times 1.73 \times pf) / 1000$	kVA x pf
kVA	$(U \times I \times 1.73) / 1000$	kWe / pf
I (Amp)	$(kWe \times 1000) / (U \times 1.73 \times pf)$	$(kVA \times 1000) / (U \times 1.73)$
Frequency	$(Rpm \times N^{\circ}Pole) / (2 \times 60)$	
Rpm	$(2 \times 60 \times Frequency) / N^{\circ}Pole$	

kWm: Mechanical Power

kWe : Electrical Power

pf : Power factor

E : Alternator efficiency

I : Current (A)

U : Voltage (V)

kVA : Power

Rpm: Revolutions per minute

General Dimensions

Standard Generator

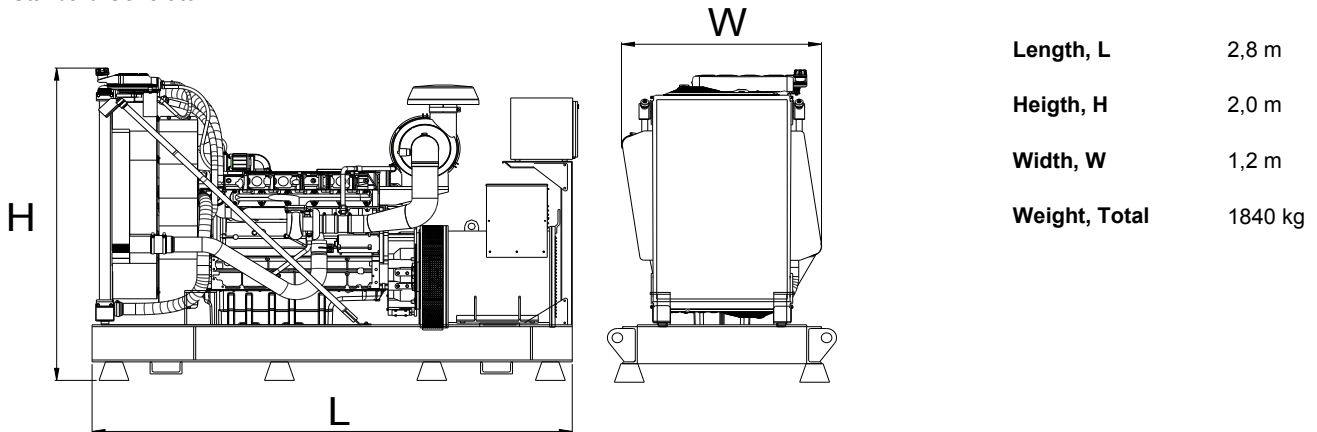

Generator with Soundproof Canopy

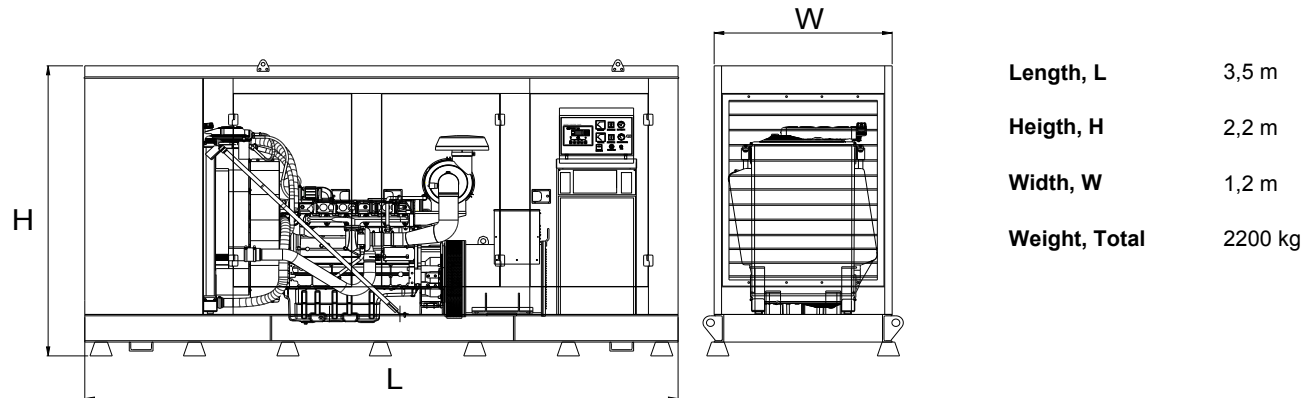

Generator Room Layout

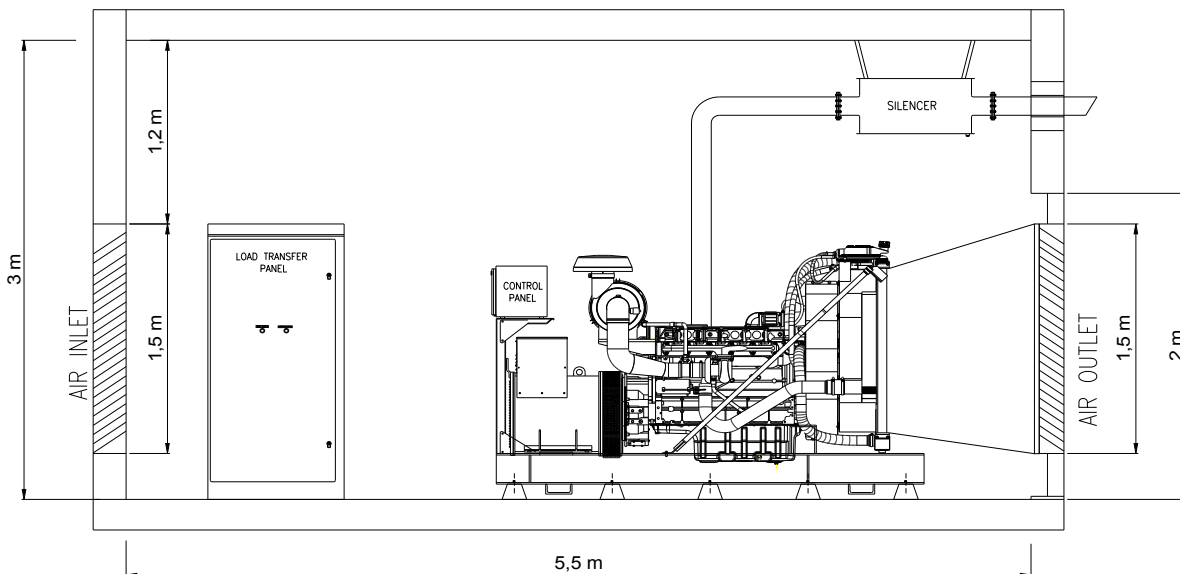

Above drawings dimensions and weights are only for guidance. For installation design of your specific application, necessary certified drawings, at site consultancy service as well as maintenance and installations manuals will be provided by Cukurova without any charge.

Specifications may change without notice

	CUKUROVA JENERATOR SANAYII TICARET A.S.	
	<p>Izmir Factory Aegean Free Zone, Boss Sokak No:11, Gaziemir - Izmir, Turkey Tel : +90 232 252 2026 Fax : +90 232 252 2027</p>	<p>Istanbul Export Sales Office Ankara Yolu, Tuzla Tersane Kavşagi No:26 34947 Tuzla-Istanbul, Turkey Tel : +90 216 395 3460 Fax : +90 216 395 5453 Mail : info@cukurovapower.com</p>