

Perkins 1103A-33TG1 diesel engine

Newage/Stamford UCI224E alternator

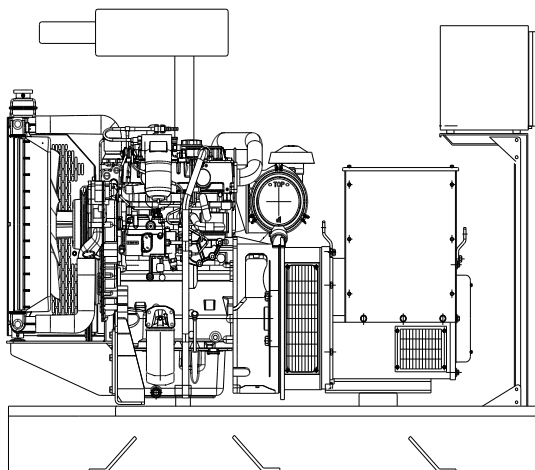

**Standard Generator Features**

- ◊ AMF, Automatic mains failure unit
- ◊ Heavy duty type, 3 cylinder, water cooled engine
- ◊ 50°C tropical type radiator
- ◊ Starter motor
- ◊ Lead acid battery
- ◊ Charging alternator
- ◊ Battery charge redressor
- ◊ Heavy duty, brushless type alternator
- ◊ Base frame with anti-vibration units
- ◊ Industrial type silencers
- ◊ Flexible exhaust compensator
- ◊ Block water heater unit
- ◊ Control panel with digital-automatic main control module
- ◊ Fan, fan drive, charging alternator drive and all rotating parts covered
- ◊ Radiator matrix covered by metal mesh against the mechanical damages
- ◊ Fabricated and welded steel base frame
- ◊ Anti-vibration mountings
- ◊ Engine and alternator manufacturer test reports
- ◊ Factory load, performance and function tests

**Optional Features**

- ◊ Automatic load transfer panel
- ◊ Automatic synchronization and power sharing systems
- ◊ Soundproof canopy
- ◊ Container type enclosures
- ◊ Road trailer
- ◊ Job-site trailer
- ◊ Protection circuit breaker
- ◊ Air start
- ◊ Remote type radiator
- ◊ Base fuel tank
- ◊ External type fuel tank
- ◊ Automatic fuel transfer system
- ◊ Residential silencer



Model	Standby		Prime	
	kVA	kW	kVA	kW
<b>CJ65PN</b>	<b>63</b>	<b>50,4</b>	<b>59,7</b>	<b>47,7</b>

**APPLICATION DATA**

**Perkins 1103A-33TG2 Engine**

**Standard Features**

**Compact, efficient power**

- ◊ 1100 Series is the result of an intensive period of customer research that has guided the development of the range.
- ◊ The new 3.3 litre cylinder block ensures bore roundness is maintained under the pressures of operation. It also ensures combustion and mechanical noise is lowered.
- ◊ A new cylinder head has re-established Perkins mastery of air control.

**Quality by Design**

- ◊ Product design and Class A manufacturing improvements enhance product reliability while maintaining Perkins legendary reputation for durability.

**Cost Effective Power**

- ◊ Compact size and low noise.
- ◊ Lower fuel consumption and oil use.
- ◊ 500 hour service intervals.

**Product Support**

- ◊ Total worldwide service is provided through a network of 4,000 distributors and dealers.
- ◊ TIPSS - The Integrated Parts and Support System enables customers to specify and order parts electronically as well as service engines with on-line guides and service tools.

**Technical Specifications**

Manufacturer	PERKINS
Model	1103A-33TG2
Type	4 cycle, water-cooled, diesel engine
Number of cylinders	3
Cylinder arrangement	Vertical in-line
Displacement, Liters	3.3
Bore X Stroke, mm	105 X 127
Compression Ratio	17.25:1
Combustion System	Direct injection
Aspiration	Turbocharged
Rotation	Clockwise viewed from front
Gross engine power, kWb	60.5
Fan Power, kWm	1,2
BMEP gross, bar	14.67
Combustion air flow, m <sup>3</sup> / min	3.9
Exhaust gas temp.(after turbo), °C	571
Exhaust gas flow (after turbo),m <sup>3</sup> / min	10.4
Mean piston speed, m / s	6.35

**Cooling System**

Type	Tropical, heavy duty type
Ambient temperature, °C	50
Engine+Radiator coolant cap., Liters	10.2
Pressure cap setting, kPa	107
◊ Thermostatically-controlled system with belt driven circulating pump and pusher fan	
◊ Mounted radiator piping and guards	

Model	Standby kW		Prime kW	
	Gross	Net	Gross	Net
<b>1103A-33TG2</b>	<b>60.5</b>	<b>59.3</b>	<b>55</b>	<b>53.8</b>

**Lubricating System**

Type	Pressurized
Capacity, Liters	8.3
Lub oil pressure (min), kPa	415-470
◊ Wet sump with filler and dipstick	
◊ Spin-on full-flow lub oil filter	

**Fuel System**

Type of injection system	Direct injection
Fuel atomiser	Multi-hole
Fuel injection Pump	Rotary
Delivery/hour at 1500rev/min, Liters	120-150
Governor type	Mechanical
◊ Electronic governor speed control to ISO8528-G2	
◊ Rotary type pump	
◊ Ecoplus fuel filter	

**Electrical System**

Alternator	12 Volt, 65 Amp
Starter motor (DC)	12 Volt
Starter motor power	3 kW
◊ Oil pressure and coolant temperature switches	
◊ 12 volt shut off solenoid energised to run	
◊ Glow plug cold start aid and heater/starter switch	

**Fuel Consumption**

liters per hour	%110 Load	15,4 L
	%100 Load	13,9 L
	%75 Load	10,4 L
	%50 Load	7,2 L
grams per kWh	%110 Load	3,3 gal/h
	%100 Load	3,0 gal/h
	%75 Load	2,2 gal/h
	%50 Load	1,5 gal/h

# alternator

## Newage/Stamford UCI224E Alternator

### Standard Features

#### Winding&Electrical Performance

All generator stators are wound to 2/3 pitch. This eliminates triplen (3rd, 9th, 15th...) harmonics on the voltage waveform and is found to be the optimum design for trouble-free supply of non-linear loads. The 2/3 pitch design avoids excessive neutral currents sometimes seen with higher winding pitches, when in parallel with the mains. A fully connected damper winding reduces oscillations during paralleling. This winding, with the 2/3 pitch and carefully selected pole and tooth designs, ensures very low waveform distortion.

#### SX460 AVR

With this self excited control system the main stator supplies power via the Automatic Voltage Regulator (AVR) to the exciter stator. The high efficiency semiconductors of the AVR ensure positive build-up from initial low levels of residual voltage.

This exciter rotor output is fed to the main rotor through a three phase full wave bridge rectifier. This rectifier is protected by a surge suppressor against surges caused, for example, by short circuit.

#### Terminals&Terminal Box

Standard generators are 3-phase reconnectable with 12 ends brought out to the terminals, which are mounted on a cover at the non-drive end of the generator. A sheet steel terminal box contains the AVR and provides ample space for the customer's wiring and gland arrangements. It has removable panels for easy access.

#### Shaft&Keys

All generator rotors are dynamically balanced to better than BS6861:Part 1 Grade 2.5 for minimum vibration in operation. Two bearing generators are balanced with a half key.

#### Insulation / Impregnation

The insulation system is class 'H'

All wound components are impregnated with materials and processes designed specifically to provide the high build required for static windings and the high mechanical strength required for rotating components.

#### Standards

Newage Stamford industrial generators meet the requirements of **BS EN 60034** and the relevant section of other international standards such as **BS5000, VDE0530, NEMA MG1-32, IEC34, CSA C22.2-100, AS1359**. Other standards and certifications can be considered on request.

#### Quality Assurance

Generators are manufactured using production procedures having a quality assurance level to BS EN ISO 9001.

Model	Standby		Prime	
	kVA	kW	kVA	kW
<b>UCI224E</b>	<b>63</b>	<b>50,4</b>	<b>60</b>	<b>48</b>

### Technical Specifications

Manufacturer	NEWAGE / STAMFORD
Model	UCI224E
Type	4-Poles, Rotating Field, Brushless
Standby power at rated voltage, kVA	63
Efficiency, %	88,5
Power factor	0.8
Phase	3
Frequency, Hz	50
Speed, Rpm	1500
Voltage, V	380/415
Excitation	Self excited
Stator windings	2/3 Pitch factor
Regulation	AVR, Automatic Voltage Regulator
Voltage Regulator	SX460
Voltage Regulation, %	± 1.5
R.F.I Suppression	BS EN 61000-6-2 & BS EN 61000-6-4 VDE0875G, VDE 0875N
Waveform distortion	No Load <1.5% Non distorting balanced linear load <5.0%
Rotor	Dynamic balanced
Overspeed, Rpm	2250
Short circuit current	< 300%
TIF	Less than 50
Insulation class	H
Construction	Single bearing, direct coupled
Coupling	Flexible
Stator winding	Double layer concentric
Connection	WYE
Protection class	IP23
Cooling air volume, m <sup>3</sup> / sec	0.216

### Optional Equipment

- ◊Optional Permanent Magnet Generator (PMG) provides an isolated power supply to the excitation control system
- ◊Anti Condensation Heaters
- ◊Air Filters
- ◊Temperature Indication RTD's
- ◊Winding Protection Thermistors
- ◊Quadrature Droop kit for Parallel Operation
- ◊SX440 AVR with 1% Regulation and 2 Phase Sensing
- ◊SX421 AVR with 3 Phase Sensing and improved Regulation 0.5%
- ◊MX341 (PMG) 1% Regulation with 2 Phase Sensing
- ◊MX321 (PMG) with 3 Phase Sensing and improved Regulation 0.5%

## Control Panel

### Standard Equipments

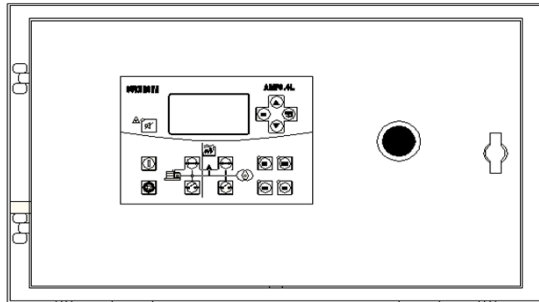

- ◊ AMF 3.4L graphical LCD display with white back light
- ◊ Emergency stop button

## AMF 3.4L Control Module

### Description

- ◊ The model AMF 3.4L is an automatic mains failure control module.
- ◊ The modul is used to monitor a mains supply and automatically start a standby generator set.
- ◊ The module also provides indication of operational status and fault conditions
- ◊ automatically shutting down the genset and indicating failures by means of an LCD display, and appropriate flashing LED on the front panel.
- ◊ Selected timers and alarms can be altered by the user from the front panel.
- ◊ Phase sequence detection and reverse power detection.
- ◊ Real time clock and time stamped alarm logging

### Specifications

- ◊ 17,85mm x 125,6mm dimensions
- ◊ 128x64 screen LED display.
- ◊ IP52
- ◊ Easy comprehended display .
- ◊ LED mimic diagram
- ◊ Easy pushbutton controls
- ◊ System parameters can be adjusted manually from the front panel
- ◊ kVA, kW ve  $\cos\phi$  measurements
- ◊ Recording of the last 15 failure alarm.
- ◊ Battery saving sleep mode function.
- ◊ Pre-glow heater control
- ◊ True RMS voltage and current measurements for mains and generator.
- ◊ 8 digital inputs , 6 digital outputs (Dry Contact)

### Pushbutton Controls

STOP / START  
 AUTO, TEST, MANUAL  
 LCD PAGE

### Input Functions display on LCD

Generator Volts	Volts L1-N, L2-N, L3-N
Generator Volts	Volts L1-L2, L2-L3, L3-L1
Generator Amps	Amps L1, L2, L3
Generator Frequency	Hz
Mains Volts	Volts L1-N, L2-N, L3-N
Mains Volts	Volts L1-L2, L2-L3, L3-L1
Mains Kva, Kw, Kvar, Kvarh	L1-N, L2-N, L3-N
Generator Kva, Kw, Kvar, Kvarh	L1-N, L2-N, L3-N
Power Factor	cos $\phi$
Mains Frequency	Hz
Engine Speed	RPM
Plant Battery Volts	Volts
Engine Hours Run	Hour

### Optional Functions

Engine Oil pressure	kPa
Engine Temperature	$^{\circ}$ C
Service Hours Timing Function	
SCADA Interface For Monitoring And Remote System Programming	
GSM Modem Interface (SMS options)	
Remote Start-Stop Interface	
Modbus Rtu Communication Interface Port	

### Alarm Channels

Engine Start/Stop Failure
Over-Current
Under/Over Generator Frequency
Under/Over Speed
Charge Fail
Emergency Stop
Low Oil Pressure
High Engine Temperature
Under/Over Generator Voltage
Loss Of Speed Sensing Signal
Mains Out Of Limits

### Environmental Testing Standards

#### Electromagnetic Compatibility

K-Q TSE ISO 9000

#### Temperature

Cold : -25 $^{\circ}$ C

Hot : + 70 $^{\circ}$ C

#### Humidity

%10-95 non-condensing

**Model Codes and General Information**

Cukurova Diesel Generator

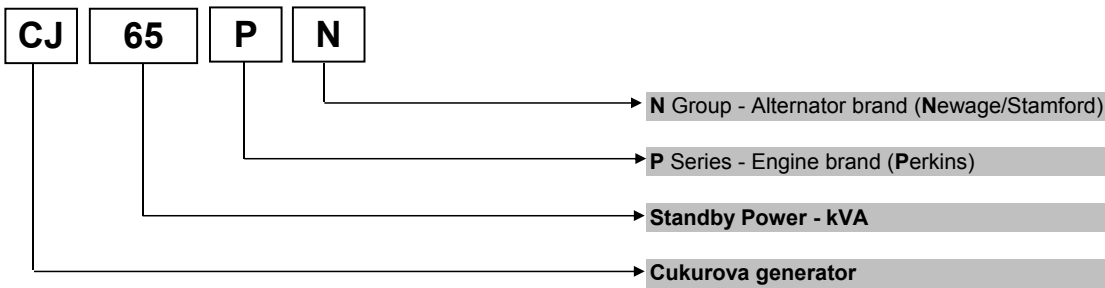

Perkins 1100 Series Diesel Engine

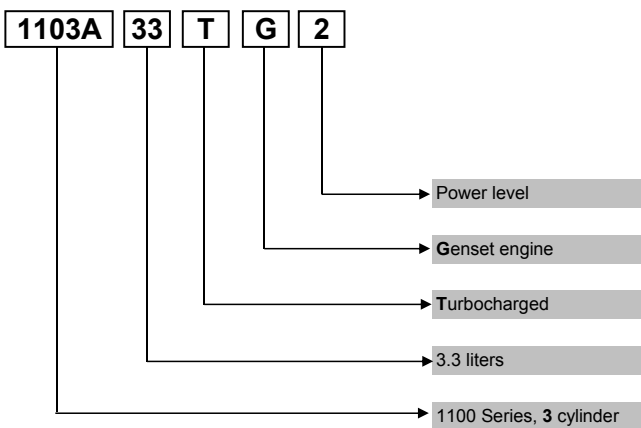

Newage / Stamford Alternator

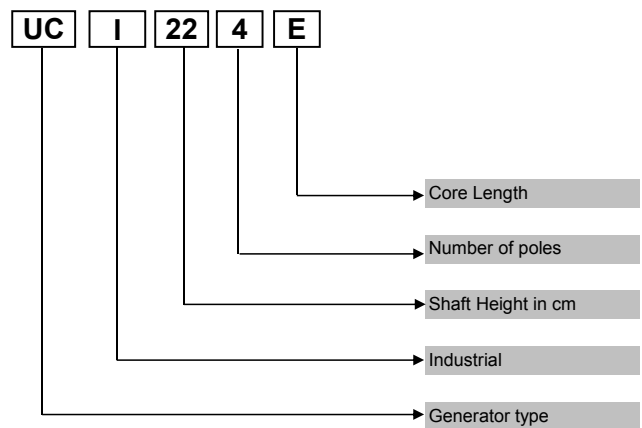

**Information**

**Power Ratings**

**Standby power rating** is for the supply of emergency power at variable load for the duration of the non-availability of the mains power supply.No overload capacity is available at this rating.A standby rated engine should be sized for an average load factor of 80% based on published standby rating for 500 operating hours per year.Standby ratings should never be applied except in true emergency power failure conditions.

**Prime power rating** is available for unlimited hours per year with a variable load of which the average engine load factor is 80% of the published power rating, incorporation of a 10% overload for 1 hour in every 12 hours of operation which permitted

**Continuous power rating** is available for continuous full load operation.No overload is permitted.

Acc. to ISO 3046/1, BS 5514, DIN6271

**Electric Formulas**

Values	Formula	
kWe	kWm X E	
kWe	$(U \times I \times 1.73 \times pf) / 1000$	kVA x pf
kVA	$(U \times I \times 1.73) / 1000$	kWe / pf
I (Amp)	$(kWe \times 1000) / (U \times 1.73 \times pf)$	$(kVA \times 1000) / (U \times 1.73)$
Frequency	$(Rpm \times N^{\circ}Pole) / (2 \times 60)$	
Rpm	$(2 \times 60 \times Frequency) / N^{\circ}Pole$	

**kWm**: Mechanical Power

**kWe** : Electrical Power

**pf** : Power factor

**E** : Alternator efficiency

**I** : Current (A)

**U** : Voltage (V)

**kVA** : Power

**Rpm**: Revolutions per minute

**General Dimensions**

Standard Generator

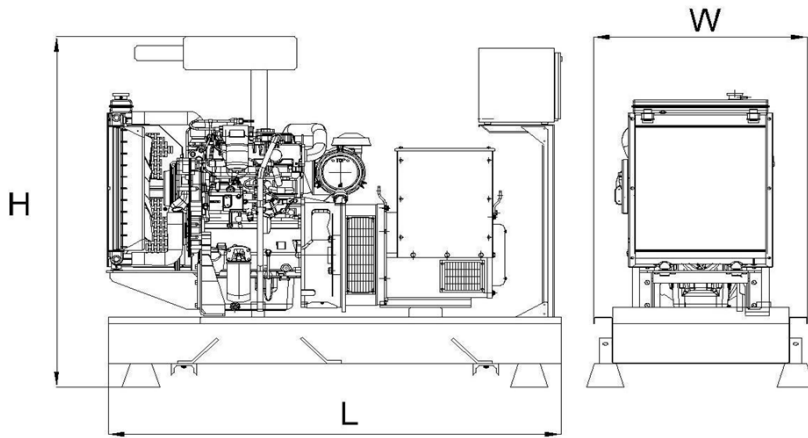

<b>Length, L</b>	1,8 m
<b>Height, H</b>	1,45 m
<b>Width, W</b>	0,85 m
<b>Weight, Total</b>	1000 kg

Generator with Soundproof Canopy

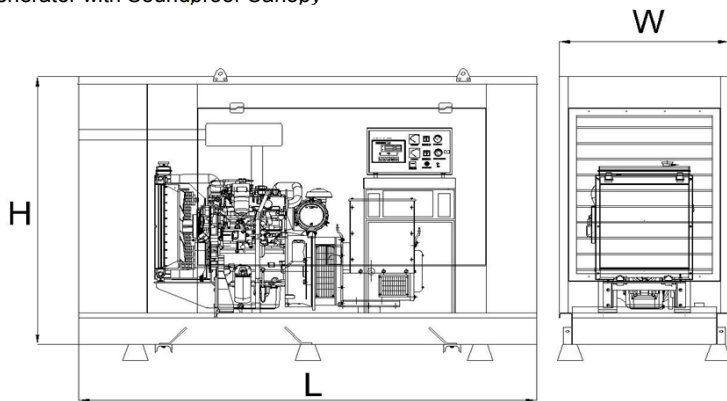

<b>Length, L</b>	2,45 m
<b>Height, H</b>	1,85 m
<b>Width, W</b>	1 m
<b>Weight, Total</b>	1400kg

**Generator Room Layout**

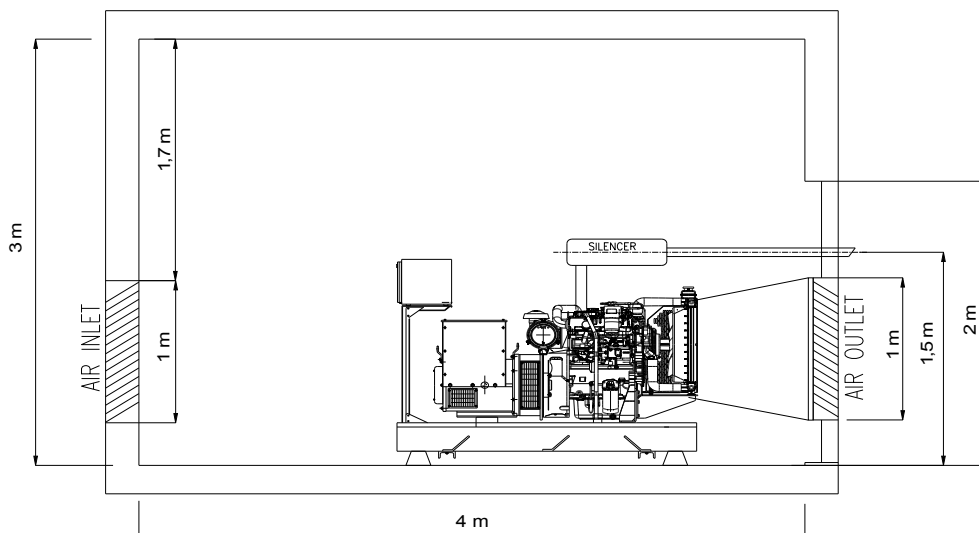

Above drawings dimensions and weights are only for guidance. For installation design of your specific application, necessary certified drawings, at site consultancy service as well as maintenance and installations manuals will be provided by Cukurova without any charge. Specifications may change without notice

	<p><b>CUKUROVA JENERATOR SANAYII TICARET A.S.</b></p> <p><u>Izmir Factory</u>                  Aegean Free Zone, Boss Sokak                  No:11, Gaziemir - Izmir, Turkey                  Tel : +90 232 252 2026                  Fax : +90 232 252 2027</p>
--	--