

Perkins 2806A-E18TAG1A diesel engine

Newage/Stamford HCI544E alternator

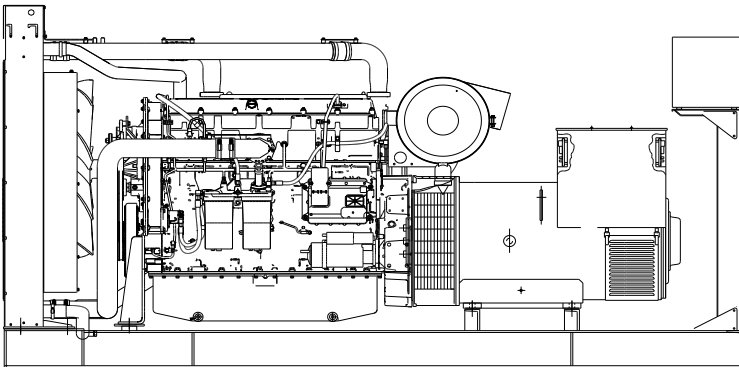

Standard Generator Features

- ◊ AMF, Automatic mains failure unit
- ◊ Heavy duty type, 6 cylinder, water cooled engine
- ◊ 50°C tropical type radiator
- ◊ Starter motor
- ◊ Lead acid battery
- ◊ Charging alternator
- ◊ Battery charge redressor
- ◊ Heavy duty, brushless type alternator
- ◊ Base frame with anti-vibration units
- ◊ Industrial type silencers
- ◊ Flexible exhaust compensator
- ◊ Block water heater unit
- ◊ Control panel with digital-automatic main control module
- ◊ Fan, fan drive, charging alternator drive and all rotating parts covered
- ◊ Radiator matrix covered by metal mesh against the mechanical damages
- ◊ Fabricated and welded steel base frame
- ◊ Anti-vibration mountings
- ◊ Engine and alternator manufacturer test reports
- ◊ Factory load, performance and function tests

Optional Features

- ◊ Automatic load transfer panel
- ◊ Automatic synchronization and power sharing systems
- ◊ Soundproof canopy
- ◊ Container type enclosers
- ◊ Road trailer
- ◊ Job-site trailer
- ◊ Protection circuit breaker
- ◊ Air start
- ◊ Remote type radiator
- ◊ Base fuel tank
- ◊ External type fuel tank
- ◊ Automatic fuel transfer system
- ◊ Residential silencer



Model	Standby		Prime	
	kVA	kW	kVA	kW
CJ670PN	665	532	610	488

APPLICATION DATA

Perkins 2806A-E18TAG1A Engine

Standard Features

Economic power

◊Mechanically operated unit fuel injectors with electronic control combined with carefully matched turbocharging give excellent fuel atomisation and combustion with optimum economy

◊Low emissions result from electronic control of fuel injected

Reliable power

◊Developed and tested using latest engineering techniques and finite element analysis for high reliability, low oil usage and low wear rates

◊High compression ratios also ensure clean rapid starting in all conditions

◊Support comes from a worldwide network of 4000 distributors and dealers

Compact and efficient power

◊Exceptional power to weight ratio and compact size give optimum power density with easier installation and cost effective transportation

◊Designed to provide excellent service access for ease of maintenance

Clean Power

◊The 2806-E18TAG1A is capable of meeting the requirements of TA luft (1986)

Standards

◊ UK MOD, BS5750, ISO9001, BS5514/1-1982, ISO 3046/1, ISO 8528/1

Technical Specifications

Manufacturer	PERKINS
Model	2806A-E18TAG1A
Type	4 cycle, water-cooled, diesel engine
Number of cylinders	6
Cylinder arrangement	Vertical in-line
Displacement, Liters	18.1
Bore X Stroke, mm	145 X 183
Compression Ratio	14.5:1
Combustion System	Direct injection
Aspiration	Turbocharged, air-to-air charge cooled
Rotation	Anti-clockwise viewed on flywheel
Gross engine power, kWb	593
Fan Power, kWm	9
BMEP gross, bar	26,15
Combustion air flow, m ³ / min	36
Exhaust gas temp.(after turbo), °C	571
Exhaust gas flow (after turbo),m ³ / min	104
Mean piston speed, m / s	9

Cooling System

Type	Tropical, heavy duty type
Ambient temperature, °C	50
Engine+Radiator coolant cap., Liters	61
Jacket coolant flow, Liters / sec	6.1
Cooling min airflow, m ³ / min	702
◊Gear-driven circulating pump	
◊Mounted belt-driven pusher fan	
◊Radiator incorporating air-to-air charge cooler, (supplied loose)	
◊System designed for ambients up to 50°C	
◊Low coolant level switch	

Model	Standby kW		Prime kW	
	Gross	Net	Gross	Net
2806A-E18TAG1A	593	574	540	522

Lubricating System

Type	Pressurized
Capacity, Liters	55.5
Lub oil pressure (min), bar	2
◊Wet sump with filler and dipstick	
◊Full-flow replaceable 'Ecoplus' filter	
◊Oil cooler integral with filter header	

Fuel System

Type of injection system	MEUI
Fuel injection pump	Combined unit injector
Delivery/hour at 1500rev/min, Liters	413
Governor type	Electronic, governing to ISO 8528-5 class G2 with isochronous capability
◊Mechanically actuated electronically controlled unit fuel injectors with full authority electronic control	
◊Replaceable 'Ecoplus' fuel filter elements with primary filter/water separator	
◊Fuel cooler	

Electrical System

Alternator	24 Volt with integral regulator
Starter motor (DC)	24 Volt
Starter motor power	9 kW
◊ECM mounted on engine with wiring looms and sensors	
◊3 level engine protection system	

Fuel Consumption

liters per hour	%110 Load	134 L
	%100 Load	123 L
	%75 Load	90 L
	%50 Load	61 L
grams per kWh	%110 Load	201 g/kWh
	%100 Load	203 g/kWh
	%75 Load	199 g/kWh
	%50 Load	203 g/kWh

Optional Equipments

- ◊Additional speed sensor
- ◊Temperature and pressure sensors for gauges
- ◊Electric hours counter
- ◊Air filter rain hood
- ◊Twin starters/facility for second starter

alternator

Newage/Stamford HCI544E Alternator

Standard Features

Winding&Electrical Performance

All generator stators are wound to 2/3 pitch. This eliminates triplen (3rd, 9th, 15th...) harmonics on the voltage waveform and is found to be the optimum design for trouble-free supply of non-linear loads. The 2/3 pitch design avoids excessive neutral currents sometimes seen with higher winding pitches, when in parallel with the mains. A fully connected damper winding reduces oscillations during paralleling. This winding, with the 2/3 pitch and carefully selected pole and tooth designs, ensures very low waveform distortion.

SX440 AVR

With this self-excited system the main stator provides power via the Automatic Voltage Regulator (AVR) to the exciter stator. The high efficiency semi-conductors of the AVR ensure positive build-up from initial low levels of residual voltage.

The exciter rotor output is fed to the main rotor through a three-phase full-wave bridge rectifier. The rectifier is protected by a surge suppressor against surges caused, for example, by short circuit or out-of-phase paralleling.

The SX440 will support a range of electronic accessories, including a 'droop' Current Transformer (CT) to permit parallel operation with other ac generators. If 3-phase sensing is required with the self-excited system, the SX421 AVR must be used.

Terminals&Terminal Box

Standard generators are 3-phase reconnectable with 12 ends brought out to the terminals. Which are mounted on a cover at the non-drive end of the generator. A sheet steel terminal box contains the AVR and provides ample space for the customers wiring and gland arrangements. It has removable panels for easy access.

Shaft&Keys

All generator rotors are dynamically balanced to better than BS6861:Part 1 Grade 2.5 for minimum vibration in operation. Two bearing generators are balanced with a half key.

Insulation / Impregnation

The insulation system is class 'H'

All wound components are impregnated with materials and processes designed specifically to provide the high build required for static windings and the high mechanical strength required for rotating components.

Standards

Newage Stamford industrial generators meet the requirements of **BS EN 60034** and the relevant section of other international standards such as **BS5000, VDE0530, NEMA MG1-32, IEC34, CSA C22.2-100, AS1359**. Other standards and certifications can be considered on request.

Quality Assurance

Generators are manufactured using production procedures having a quality assurance level to BS EN ISO 9001.

Model	Standby		Prime	
	kVA	kW	kVA	kW
HCI544E	665	532	610	488

Technical Specifications

Manufacturer	NEWAGE / STAMFORD
Model	HCI544E
Type	4-Poles, Rotating Field, Brushless
Standby power at rated voltage, kVA	665
Efficiency Standby Power, %	94.5%
Power factor	0.8
Phase	3
Frequency, Hz	50
Speed, Rpm	1500
Voltage, V	380/415
Excitation	Self excited
Stator windings	2/3 Pitch factor
Regulation	AVR, Automatic Voltage Regulator
Voltage Regulator	SX440
Voltage Regulation, %	± 1
R.F.I Suppression	BS EN 61000-6-2 & BS EN 61000-6-4 VDE0875G, VDE 0875N
Waveform distortion	No Load <1.5% Non distorting balanced linear load<5.0%
Rotor	Dynamic balanced
Overspeed, Rpm	2250
Short circuit current	< 300%
TIF	Less than 50
Insulation class	H
Construction	Single bearing, direct coupled
Coupling	Flexible
Stator winding	Double layer concentric
Connection	WYE
Protection class	IP23
Cooling air volume, m ³ / sec	1.035

Optional Equipment

- ◊Optional Permanent Magnet Generator (PMG) provides an isolated power supply to the excitation control system
- ◊Anti Condensation Heaters
- ◊Air Filters
- ◊Temperature Indication RTD's
- ◊Winding Protection Thermistors
- ◊Quadrature Droop kit for Parallel Operation
- ◊SX421 AVR with 3 Phase Sensing and improved Regulation 0.5%
- ◊MX341 (PMG) 1% Regulation with 2 Phase Sensing
- ◊MX321 (PMG) with 3 Phase Sensing and improved Regulation 0.5%

Control Panel

Standard Equipments

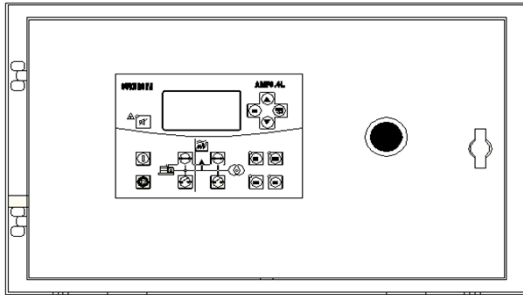

- ◊ AMF 3.4L graphical LCD display with white back light
- ◊ Emergency stop button
- ◊
- ◊
- ◊
- ◊
- ◊

AMF 3.4L Control Module

Description

- ◊ The model AMF 3.4L is an automatic mains failure control module.
- ◊ The modul is used to monitor a mains supply and automatically start a standby generator set.
- ◊ The module also provides indication of operational status and fault conditions
- ◊ automatically shutting down the genset and indicating failures by means of an LCD display, and appropriate flashing LED on the front panel.
- ◊ Selected timers and alarms can be altered by the user from the front panel.
- ◊ Phase sequence detection and reverse power detection.
- ◊ Real time clock and time stamped alarm logging

Specifications

- ◊ 17,85mm x 125,6mm dimensions
- ◊ 128x64 screen LED display.
- ◊ IP52
- ◊ Easy comprehended display .
- ◊ LED mimic diagram
- ◊ Easy pushbutton controls
- ◊ System parameters can be adjusted manually from the front panel
- ◊ kVA, kW ve cosφ measurements
- ◊ Recording of the last 15 failure alarm.
- ◊ Battery saving sleep mode function.
- ◊ Pre-glow heater control
- ◊ True RMS voltage and current measurements for mains and generator.
- ◊ 8 digital inputs , 6 digital outputs (Dry Contact)

Pushbutton Controls

STOP / START
 AUTO, TEST, MANUAL
 LCD PAGE

Input Functions display on LCD

Generator Volts	Volts L1-N, L2-N, L3-N
Generator Volts	Volts L1-L2, L2-L3, L3-L1
Generator Amps	Amps L1, L2, L3
Generator Frequency	Hz
Mains Volts	Volts L1-N, L2-N, L3-N
Mains Volts	Volts L1-L2, L2-L3, L3-L1
Mains Kva,Kw,Kvar,Kvarh	L1-N, L2-N, L3-N
Generator Kva,Kw,Kvar,Kvarh	L1-N, L2-N, L3-N
Power Factor	cosq
Mains Frequency	Hz
Engine Speed	RPM
Plant Battery Volts	Volts
Engine Hours Run	Hour

Optional Functions

Engine Oil pressure	kPa
Engine Temperature	°C
Service Hours Timing Function	
SCADA Interface For Monitoring And Remote System Programing	
GSM Modem Interface (SMS options)	
Remote Start-Stop Interface	
Modbus Rtu Communication Interface Port	

Alarm Channels

- Engine Start/Stop Failure
- Over-Current
- Under/Over Generator Frequency
- Under/Over Speed
- Charge Fail
- Emergency Stop
- Low Oil Pressure
- High Engine Temperature
- Under/Over Generator Voltage
- Loss Of Speed Sensing Signal
- Mains Out Of Limits

Environmental Testing Standards

Electromagnetic Compatibility

K-Q TSE ISO 9000

Temperature

Cold : -25°C

Hot : + 70°C

Humidity

%10-95 non-condensing

Model Codes and General Information

Cukurova Diesel Generator

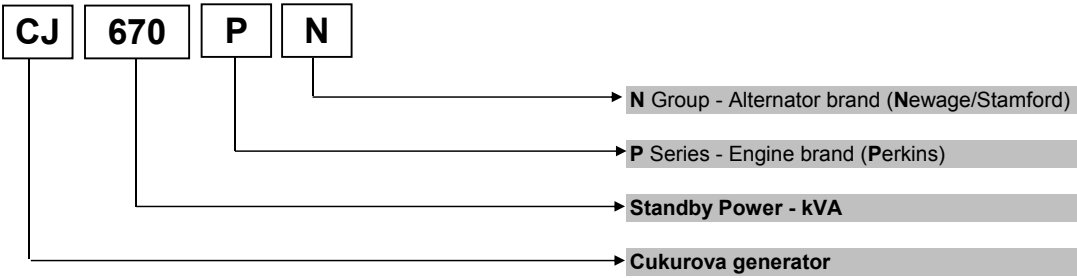

Perkins 2800 Series Diesel Engine

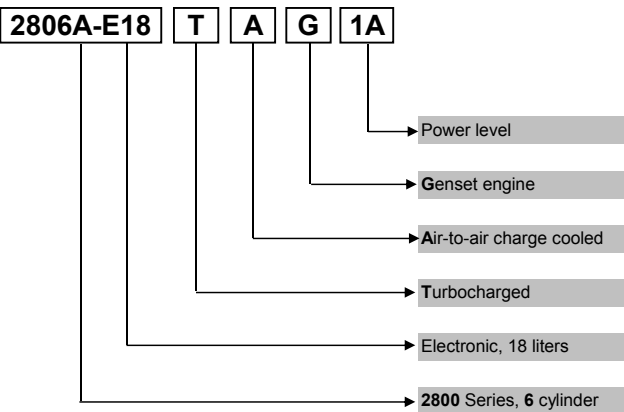

Newage/Stamford Alternator

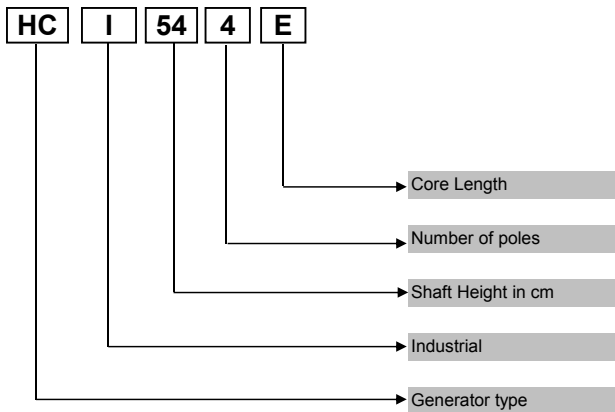

Information

Power Ratings

Standby power rating is for the supply of emergency power at variable load for the duration of the non-availability of the mains power supply. No overload capacity is available at this rating. A standby rated engine should be sized for an average load factor of 80% based on published standby rating for 500 operating hours per year. Standby ratings should never be applied except in true emergency power failure conditions.

Prime power rating is available for unlimited hours per year with a variable load of which the average engine load factor is 80% of the published power rating, incorporation of a 10% overload for 1 hour in every 12 hours of operation which permitted

Continuous power rating is available for continuous full load operation. No overload is permitted.

Acc. To ISO 3046/1, BS 5514, DIN6271

Electric Formulas

Values	Formula	
kWe	kWm X E	
kWe	$(U \times I \times 1.73 \times pf) / 1000$	kVA x pf
kVA	$(U \times I \times 1.73) / 1000$	kWe / pf
I (Amp)	$(kWe \times 1000) / (U \times 1.73 \times pf)$	$(kVA \times 1000) / (U \times 1.73)$
Frequency	$(Rpm \times N^{\circ}Pole) / (2 \times 60)$	
Rpm	$(2 \times 60 \times Frequency) / N^{\circ}Pole$	

- kWm: Mechanical Power
- kWe : Electrical Power
- pf : Power factor
- E : Alternator efficiency
- I : Current (A)
- U : Voltage (V)
- kVA : Power
- Rpm: Revolutions per minute

General Dimensions

Standard Generator

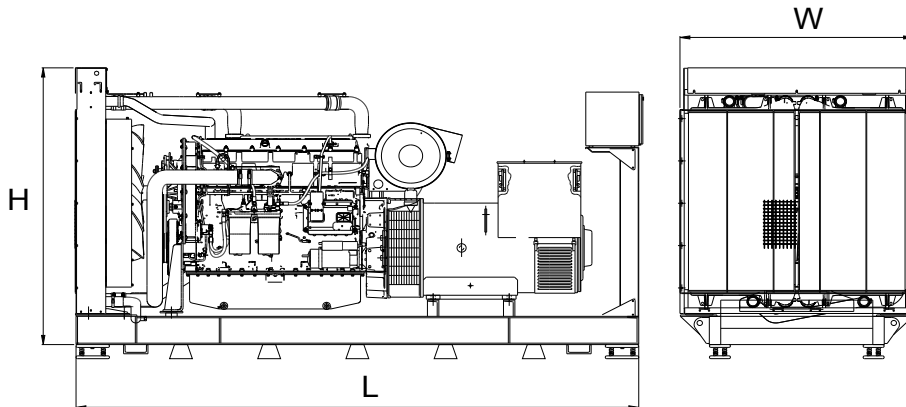

Length, L	3,7 m
Height, H	2,15 m
Width, W	1,53 m
Weight, Total	4.500 kg

Generator with Soundproof Canopy

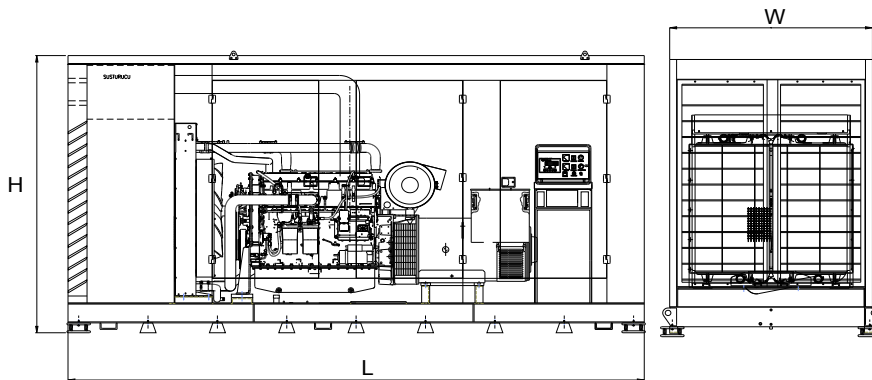

Length, L	4,6 m
Height, H	2,85 m
Width, W	1,7 m
Weight, Total	5.900 kg

Generator Room Layout

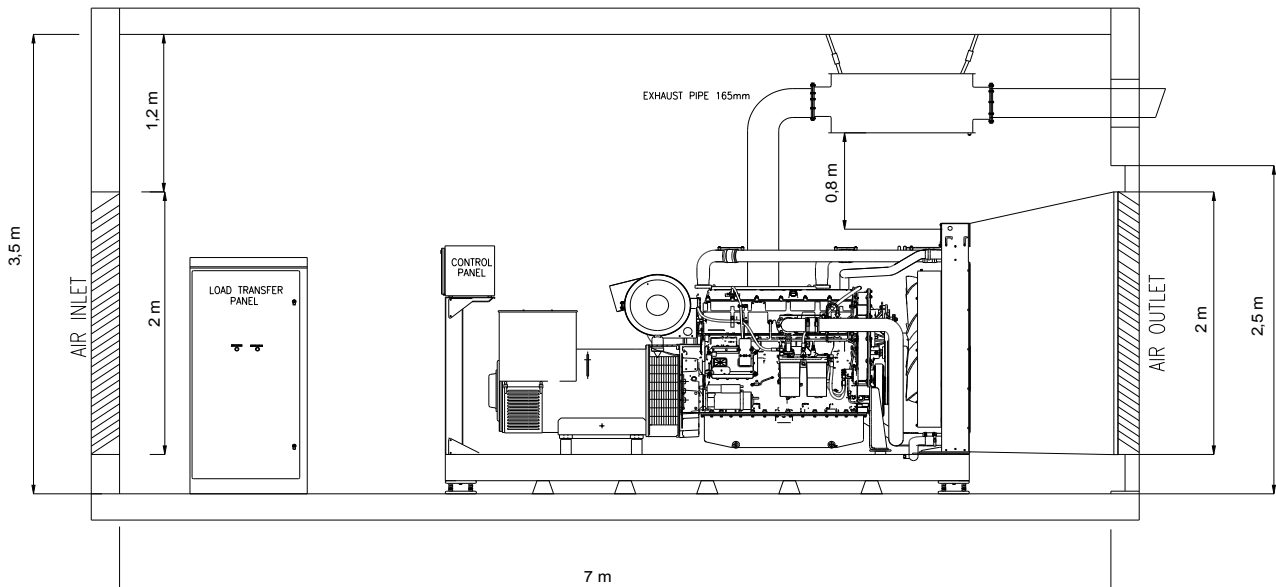

Above drawings dimensions and weights are only for guidance. For installation design of your specific application, necessary certified drawings, at site consultancy service as well as maintenance and installations manuals will be provided by Cukurova without any charge. Specifications may change without notice

<p>CUKUROVA PowerGeneration</p>	CUKUROVA JENERATOR SANAYII TICARET A.S.
	Izmir Factory
	Aegean Free Zone
	Boss Sokak
	No:11 Gaziemir
	Izmir, Turkey
Tel : +90 232 252 20 26	
Fax : +90 232 252 20 27	