

Perkins 4012-46TAG2A diesel engine

Newage/Stamford PI734C alternator

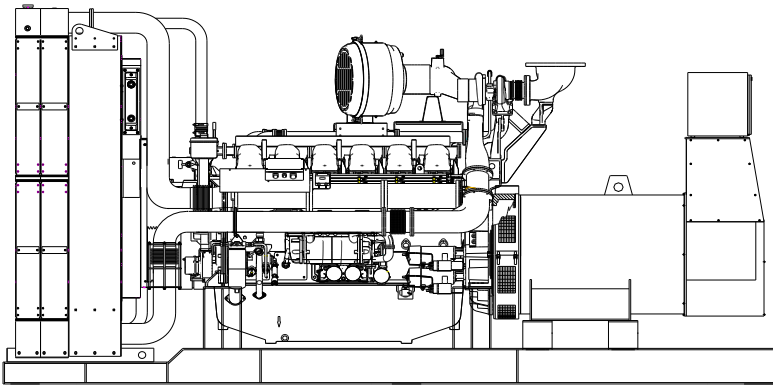

Standard Generator Features

- ◊ AMF, Automatic mains failure unit
- ◊ Heavy duty type, 12 cylinder, water cooled engine
- ◊ 50°C tropical type radiator
- ◊ Starter motor
- ◊ Lead acid battery
- ◊ Charging alternator
- ◊ Battery charge redressor
- ◊ Heavy duty, brushless type alternator
- ◊ Base frame with anti-vibration units
- ◊ Industrial type silencers
- ◊ Flexible exhaust compensator
- ◊ Block water heater unit
- ◊ Control panel with digital-automatic main control module
- ◊ Fan, fan drive, charging alternator drive and all rotating parts covered
- ◊ Radiator matrix covered by metal mesh against the mechanical damages
- ◊ Fabricated and welded steel base frame
- ◊ Anti-vibration mountings
- ◊ Engine and alternator manufacturer test reports
- ◊ Factory load, performance and function tests

Optional Features

- ◊ Automatic load transfer panel
- ◊ Automatic synchronization and power sharing systems
- ◊ Soundproof canopy
- ◊ Container type enclosures
- ◊ Road trailer
- ◊ Job-site trailer
- ◊ Protection circuit breaker
- ◊ Air start
- ◊ Remote type radiator
- ◊ Base fuel tank
- ◊ External type fuel tank
- ◊ Automatic fuel transfer system
- ◊ Residential silencer



Model	Standby		Prime	
	kVA	kW	kVA	kW
CJ1650PN	1658	1326	1511	1208

APPLICATION DATA

Perkins 4012-46TAG2A Engine

Standard Features

Economic power

◊ Individual four valve per cylinder heads give optimised gas flows, whilst digitally governed unit fuel injectors ensure ultra-fine fuel atomisation and hence controlled rapid combustion, for efficiency and economy
 ◊ Commonality of components with other engines in the 4000 Series family allows reduced parts stocking levels

Reliable power

◊ Developed and tested using latest engineering techniques
 ◊ Piston temperatures are controlled by an advanced gallery jet cooling sys.
 ◊ All engines are tolerant of a wide range of temperatures without derate
 ◊ Service is provided by the extensive Perkins network of over 4.000 distributors and dealers worldwide

Clean, efficient power

◊ New designed radiator assemblies with corrosion inhibiting powder coated finish; fewer pipe joints and easier access to reduce maintenance times
 ◊ Exceptional power to weight ratio and compact size for easier transportation and installation
 ◊ Designed to provide excellent service access for easy of maintenance
 ◊ Engines designed to comply with major international standards
 ◊ Low gaseous emissions that will satisfy the requirements of **1/2 TA Luft**

Standards

◊ UK MOD, BS5750, ISO9001, BS5514/1-1982, ISO 3046/1, ISO 8528/1

Technical Specifications

Manufacturer	PERKINS
Model	4012-46TAG2A
Type	4 cycle, water-cooled, diesel engine
Number of cylinders	12
Cylinder arrangement	60° Vee
Displacement, Liters	45.842
Bore X Stroke, mm	160 X 190
Compression Ratio	13.6:1
Combustion System	Direct injection
Aspiration	Turbocharge, air-to-air charge cooled
Rotation	Anti-clockwise viewed on flywheel
Gross engine power, kWb	1459
Fan Power, kWm	64
BMEP gross, bar	25.38
Combustion air flow, m ³ / min	128
Exhaust gas temp. (after turbo), °C	455
Exhaust gas flow (after turbo), m ³ / min	320
Mean piston speed, m / s	9,5

Cooling System

Type	Tropical, heavy duty type
Ambient temperature, °C	50
Engine coolant capacity, Liters	73
Engine+Radiator coolant cap., Liters	210
Jacket coolant flow, Liters / sec	17
Cooling min airflow, m ³ / min	1944
◊ System designed for ambients up to 50°C	
◊ Two twin thermostats	
◊ Powder coated radiator comprising: water radiator; air charge cooled radiator; fuel oil cooling (optional); all pipes, hoses and clips; fan; pulleys; fan belts and safety guards	

Model	Standby kWm		Prime kWm	
	Gross	Net	Gross	Net
4012-46TAG2A	1459	1395	1331	1267

Lubricating System

Type	Pressurized
Capacity, Liters	177
Lub oil temp. Max to bearings, °C	105
Lub oil pressure, kPa	400
◊ Wet sump with filler and dipstick	
◊ Full flow spin on oil filters	
◊ Engine jacket lub oil temperature stabilizer	

Fuel System

Type of injection system	Direct injection
Fuel injection pump	Combined unit injector
Injector pressure, MPa	140
Delivery/hour at 1500rev/min, Liters	1020
Fuel lift pump	Tuthill TCH 1-089
Governor type	Electronic governor, ISO 8528-12 CLASS 3-4; ISO 8528-5 CLASS G2
◊ Direct fuel injection system with fuel lift pump	
◊ Full flow spin-on fuel filters	

Electrical System

Alternator	24 Volt with integral regulator
Starter motor (DC)	24 Volt
Starter motor power	16.4 kW
◊ Twin high coolant temperate shutdown switches	
◊ Twin low oil pressure shutdown switches	
◊ Overspeed switch and magnetic pick up	
◊ Turbine inlet temperature shutdown switch	

Fuel Consumption

liters per hour	%110 Load	329 L
	%100 Load	297,5 L
	%75 Load	226,4 L
	%50 Load	156,8 L
grams per kWh	%110 Load	196 g/kWh
	%100 Load	194 g/kWh
	%75 Load	194 g/kWh
	%50 Load	195 g/kWh

Optional Equipments

- ◊ Fuel oil cooler integral to the radiator assembly
- ◊ Immersion heater with thermostat

alternator

Newage/Stamford PI734C Alternator

Standard Features

Winding&Electrical Performance

All generator stators are wound to 2/3 pitch. This eliminates triplen (3rd, 9th, 15th...) harmonics on the voltage waveform and is found to be the optimum design for trouble-free supply of non-linear loads. The 2/3 pitch design avoids excessive neutral currents sometimes seen with higher winding pitches, when in parallel with the mains. A fully connected damper winding reduces oscillations during paralleling. This winding, with the 2/3 pitch and carefully selected pole and tooth designs, ensures very low waveform distortion.

MX341-AVR

The PI range generators, complete with a PMG, are available with one of two AVRs. Each AVR has soft start voltage build up and built in protection against sustained over-excitation, which will de-excite the generator after a minimum of 8 seconds.

Underspeed protection (UFRO) is also provided on both AVRs. The UFRO will reduce the generator output voltage proportional to the speed of the generator below a pre-settable level.

The MX341 AVR is two phase sensed with a voltage regulation of $\pm 1\%$. Both the MX341 and MX321 need a generator mounted current transformer transformer to provide quadrature droop characteristics for load sharing during parallel operation.

Terminals&Terminal Box

Standard generators are 3-phase reconnectable with 12 ends brought out to the terminals, which are mounted on a cover at the non-drive end of the generator. A sheet steel terminal box contains the AVR and provides ample space for the customers wiring and gland arrangements. It has removable panels for easy access.

Shaft&Keys

All generator rotors are dynamically balanced to better than BS6861:Part 1 Grade 2.5 for minimum vibration in operation. Two bearing generators are balanced with a half key.

Insulation / Impregnation

The insulation system is class 'H'

All wound components are impregnated with materials and processes designed specifically to provide the high build required for static windings and the high mechanical strength required for rotating components.

Standards

Newage Stamford industrial generators meet the requirements of **BS EN 60034** and the relevant section of other international standards such as **BS5000, VDE0530, NEMA MG1-32, IEC34, CSA C22.2-100, AS1359**

Other standards and certifications can be considered on request

Quality Assurance

Generators are manufactured using production procedures having a quality assurance level to BS EN ISO 9001.

Model	Standby		Prime	
	kVA	kW	kVA	kW
PI734C	1660	1328	1550	1240

Technical Specifications

Manufacturer	NEWAGE / STAMFORD
Model	PI734C
Type	4-Poles, Rotating Field, Brushless
Standby power at rated voltage, kVA	1660
Efficiency, %	95.1%
Power factor	0.8
Phase	3
Frequency, Hz	50
Speed, Rpm	1500
Voltage, V	380/415
Excitation	Self excited
Stator windings	2/3 Pitch factor
Regulation	AVR, Automatic Voltage Regulator
Voltage Regulator	MX341
Voltage Regulation, %	± 1
R.F.I Suppression	BS EN 61000-6-2 & BS EN 61000-6-4 VDE0875G, VDE 0875N
Waveform distortion	No Load <1.5% Non distorting balanced linear load <5.0%
Rotor	Dynamic balanced
Overspeed, Rpm	2250
Short circuit current	< 300%
TIF	Less than 50
Insulation class	H
Construction	Single bearing, direct coupled
Coupling	Flexible
Stator winding	Double layer concentric
Connection	WYE
Protection class	IP23
Cooling air volume, m ³ / sec	2.69

Optional Equipment

- ◊ Winding and bearings RTD's
- ◊ Winding Protection Thermistors
- ◊ Anti Condensation Heaters
- ◊ Air Filters
- ◊ Quadrature Droop kit for Parallel Operation
- ◊ Power Factor Controller
- ◊ Diode Failure Unit
- ◊ Excitation Loss Module
- ◊ Manual Voltage Regulator
- ◊ Re-greased bearings
- ◊ MX321 AVR with 0.5% Regulation and 3 phase sensing

Control Panel

Standard Equipments

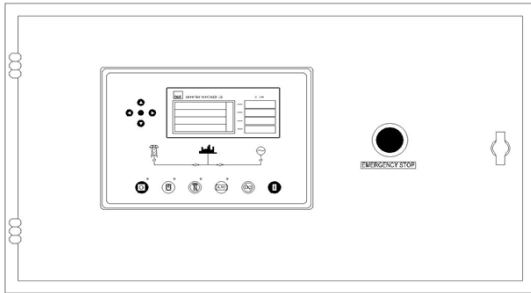

- ◊Deeapse 7320 digital automatic control module
- ◊Emergency stop button
- ◊
- ◊
- ◊
- ◊

Deepsea 7320 Control Module

Description

- ◊The model 7320 is an Automatic Mains Failure Control module.
- ◊The modul is used to monitor a mains supply and automatically start a standby generator set.
- ◊The module also provides indication of operational status and fault conditions automatically shutting down the genset and indicating failures by means of an LCD display, and appropriate flashing LED on the front panel.
- ◊Selected timers and alarms can be altered by the user from the front panel.
- ◊Alterations to the system are made using USB and a PC. This interface also provides real time diagnostic facilities

Specifications

- ◊240mm x 181mm dimensions
- ◊70mm x 40mm dimensions, 4 segment grafical LCD monitor
- ◊Developed 16-bit Microprocessor design
- ◊Easy comprehended display (Hid-Til-Lit SMD LED technology)
- ◊LED mimic diagram
- ◊SMS messaging capability with suitable GSM Modem
- ◊PC software is MS Windows based and allows the operator to control the module from a remote location (with USB)
- ◊Easy pushbutton controls
- ◊System parameters can be adjusted manually from the front panel
- ◊kVA,kW ve Cosφ measurements
- ◊Communication with MODEM / Ethernet
- ◊Modbus RTU
- ◊User selectable RS232 or RS485 communications.
- ◊4 analog inputs, 8 digital inputs, 6 digital outputs

Pushbutton Controls

STOP / START
 AUTO, TEST, MANUAL
 LCD PAGE

Input Functions display on LCD

Generator Volts	Volts L1-N, L2-N, L3-N
Generator Volts	Volts L1-L2, L2-L3, L3-L1
Generator Amps	Amps L1, L2, L3
Generator Frequency	Hz
Mains Volts	Volts L1-N, L2-N, L3-N
Mains Volts	Volts L1-L2, L2-L3, L3-L1
Mains Frequency	Hz
Engine Speed	RPM
Plant Battery Volts	Volts
Engine Hours Run	Hour
Generator Total Power	kVA L1, L2, L3,total
Generator Total Power	kW L1, L2, L3,total
Generator Power Factor	Cosφ L1, L2, L3,total

Optional Input Functions

Engine Oil pressure	kPa
Fuel Level	%
Engine Temperature	°C

Alarm Channels

Under/Over Generator Voltage
 Over-Current
 Under/Over Generator Frequency
 Under/Over Speed
 Charge Fail
 Emergency Stop
 Low Oil Pressure
 High Engine Temperature
 Fail to Start
 Low/High DC Battery Voltage
 Reverse Power
 Generator Phase Rotation Error
 Reverse Power
 Loss of Speed Sensing Signal
 Mains Out of Limits

Environmental Testing Standards

Electromagnetic Compatibility

BS EN 50081-2:1992 and EN 61000-6-4:2000 EMC, Emission Standards for the Industrial Environment

EN 61000-6-2:1999 EMC, Immunity Standards for the Industrial Environment

Vibration

BS EN 60068-2-6 Ten sweeps (up and back down) at 1 octave/minute in each of the three major axes.

5Hz to @ +/-7.5mm constant displacement.

8Hz to 500Hz 2gn constant acceleration.

Temperature

Cold : BS EN 60068-2-1 to -30°C

Hot : BS EN 60068-2-2 to 70°C

Humidity

BS EN 2011 part 2.1 93% RH @ 40° for 48 hours

Shock

BS EN 6068-2-27 Three half sine shocks in each of the three major axes 15gn amplitude.11mS duration.

Electrical Safety

BS EN 60950 Low Voltage Directive/Safety of information technology equipments, including electrical business equipment

Model Codes and General Information

Cukurova Diesel Generator

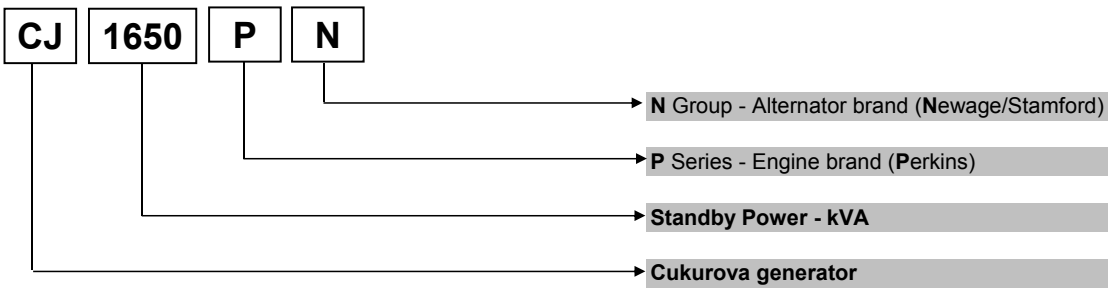

Perkins 4000 Series Diesel Engine

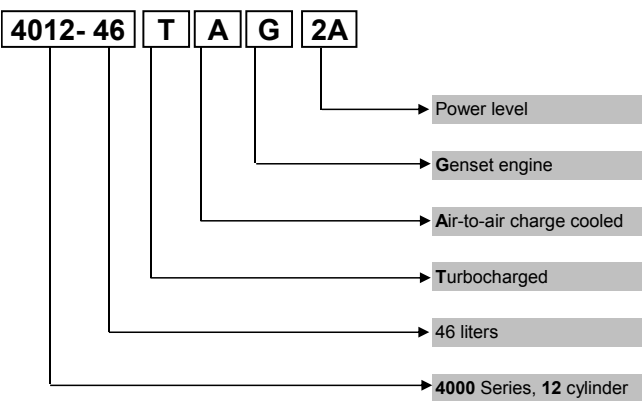

Newage/Stamford Alternator

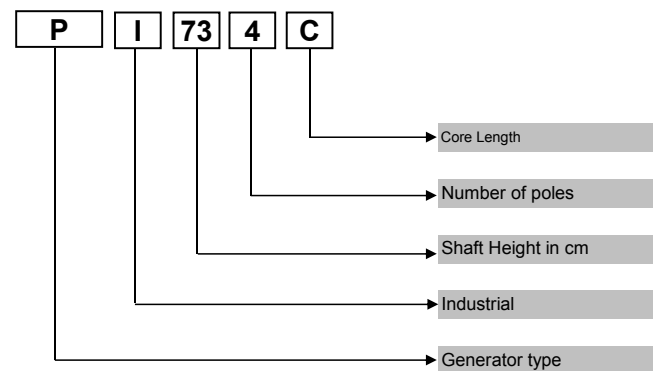

Information

Power Ratings

Standby power rating is for the supply of emergency power at variable load for the duration of the non-availability of the mains power supply. No overload capacity is available at this rating. A standby rated engine should be sized for an average load factor of 80% based on published standby rating for 500 operating hours per year. Standby ratings should never be applied except in true emergency power failure conditions.

Prime power rating is available for unlimited hours per year with a variable load of which the average engine load factor is 80% of the published power rating, incorporation of a 10% overload for 1 hour in every 12 hours of operation which permitted

Continuous power rating is available for continuous full load operation. No overload is permitted.

Acc. to 3046/1, BS 5514, DIN6271

Electric Formulas

Values	Formula	
kWe	kWm X E	
kWe	$(U \times I \times 1.73 \times pf) / 1000$	kVA x pf
kVA	$(U \times I \times 1.73) / 1000$	kWe / pf
I (Amp)	$(kWe \times 1000) / (U \times 1.73 \times pf)$	$(kVA \times 1000) / (U \times 1.73)$
Frequency	$(Rpm \times N^{\circ}Pole) / (2 \times 60)$	
Rpm	$(2 \times 60 \times Frequency) / N^{\circ}Pole$	

kWm: Mechanical Power
kWe: Electrical Power
pf: Power factor
E: Alternator efficiency

I: Current (A)
U: Voltage (V)
kVA: Power
Rpm: Revolutions per minute

General Dimensions

Standard Generator

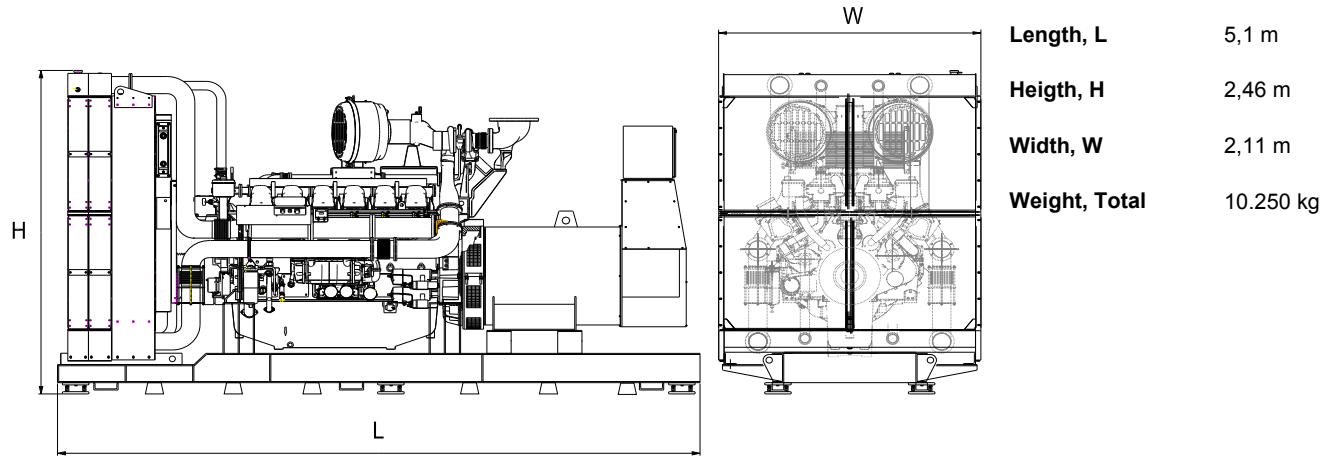

Generator Room Layout

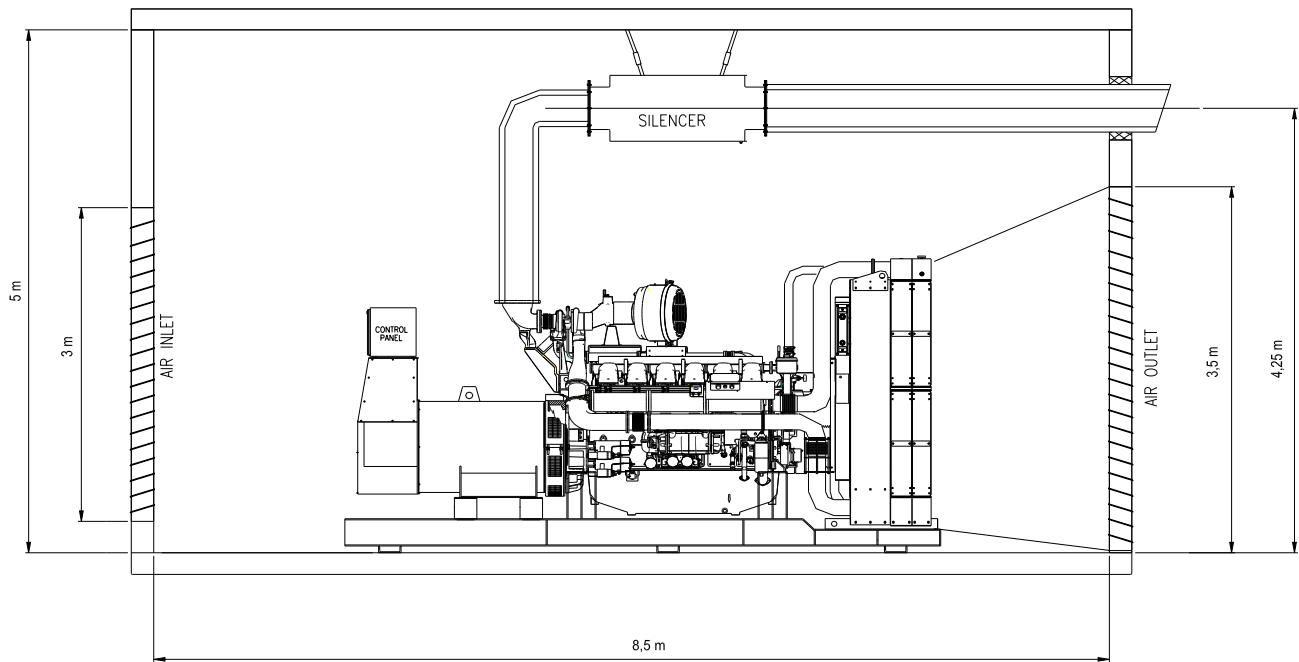

Above drawings dimensions and weights are only for guidance. For installation design of your specific application, necessary certified drawings, at site consultancy service as well as maintenance and installations manuals will be provided by Cukurova without any charge. Specifications may change without notice

	<p>Head Office Ankara Caddesi No:194 Bornova / Izmir Tel : +90 232 252 20 26 Fax : +90 232 252 20 27 izm@cukurovapower.com</p>	<p>Istanbul E-5 Yan yol üzeri Orta Mah. Kanuni Sokak No:1 Kartal / Istanbul Tel : +90 216 625 15 00 Fax : +90 216 451 22 30 istanbul@cukurovapower.com</p>	<p>Adana Zeytinli Mah. T.Cemal Beriker Blv. No:695 Seyhan / Adana Tel : +90 322 441 00 99 Fax : +90 322 441 11 21 cukurovajenerator@cukurovapower.com</p>
	<p>ÇUKUROVA JENERATÖR SANAYİİ TİCARET A.Ş.</p>		